

SIMON-AIRE INC. 2018

# SIMON-AIRE INC.



SIMON-AIRE INC. 2019

## NEW CONSTRUCTION REPLACEMENT PTAC UNITS WATER SOURCE HP

SIMON-AIRE INC. 746 East 9th Street, New York 10009  
Tel: 212-254-8372  
Fax: 646-349-5921  
E-mail: [engineering@simon-aire.com](mailto:engineering@simon-aire.com) / [sales@simon-aire.com](mailto:sales@simon-aire.com)  
[www.simon-aire.com](http://www.simon-aire.com)





## »»» contents

<u>02 OUR MISSION STATEMENT</u>	
<u>03 WHO WE ARE</u>	
<u>04 MODEL CROSS REFERENCE</u>	
<u>05 STANDARD FEATURES</u>	
<u>06 SSNY/SSCT</u>	
<u>08 SSHYMX</u>	
<u>10 SSK</u>	
<u>12 SS45</u>	
<u>14 SS16</u>	
<u>16 SSCM</u>	
<u>18 SSZ</u>	
<u>20 SSZHP</u>	
<u>22 SSKK-1P</u>	
<u>24 SSKK-3P</u>	
<u>26 SS41-3P</u>	

<u>28 SSAM40</u>	
<u>30 SSMXA/B</u>	
<u>32 SSMX</u>	
<u>34 SSCL</u>	
<u>36 SSNS/PTH</u>	
<u>38 SS16NS</u>	
<u>40 SSEA</u>	
<u>42 SS40</u>	
<u>44 SSWSHHP</u>	
<u>46 SSWSFCA</u>	
<u>48 PARTS&amp;ACCESSORIES</u>	
<u>50 TOUCH-PAD OPTIONS</u>	
<u>52 REMOTE CONTROLLER</u>	
<u>54 SSK ROOM ENCLOSURE</u>	
<u>56 SUBMITTAL INFORMATION</u>	

# SIMON-AIRE INC.

## OUR MISSION STATEMENT

Advanced Technology and Expertise, coupled  
With High End Dependable Features,  
Unsurpassed Quality and Customer Support.

This is the Trademark and Mission Statement of  
Simon-Aire Inc.

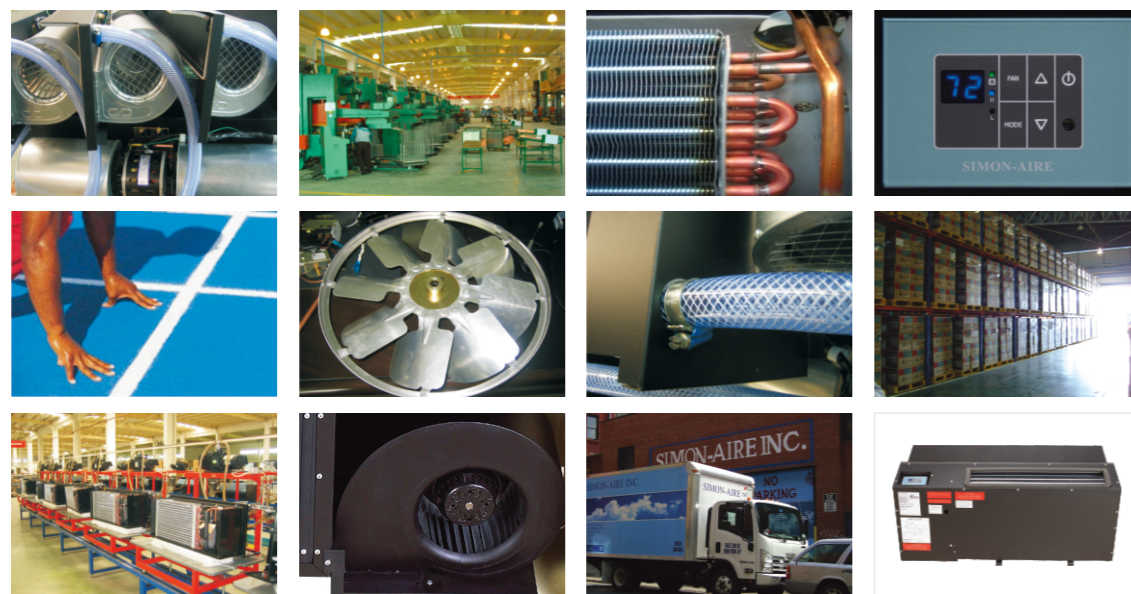

## WHO WE ARE

Simon-Aire manufactures  
Replacement Package Terminal Air  
Conditioning chassis and Water Source Heat Pumps that are  
Specifically designed to meet and exceed the demands of  
Developers, Residential Facilities, Hotels,  
Hospitals and Nursing Homes.

All Simon-Aire chassis and heat pumps include our  
"Unequaled in the Industry" Warranty.  
Two Years on all Parts and Labor.  
With additional four years on the compressor Part.



(Call Factory for details on the National Warranty Coverage)

## MODEL CROSS REFERENCE

<u>VINTAGE MAKE AND MODEL</u>	-	<u>SIMON-AIRE MODEL</u>
AMERICAN AIR FILTER SERIES 16	-	SS16
AMERICAN STANDARD TYPE 45	-	SS45
CARTERET 45	-	SS45
CLIMATE MASTER 700AD SERIES	-	SSCM
CLIMATE MASTER 702,703 & 704	-	SSCM
CARRIER 52F	-	SSHVMX
KAPSIS COOL HEAT	-	SSZ, SSZHP
EMBASSY WEATHER TWIN	-	SSZ, SSZHP
FEDDERS A AND B WALL SLEEVE	-	SSMX A/B, SSMX
FEDDERS MAXIZONE	-	SSHVMX
FRIEDRICH WALL MASTER	-	SSMX
UNI-FIT	-	SSHVMX
CLIMATE MASTER 800	-	SSWSFC
ICECAP RSK	-	SSK
RSCT	-	SSCT
SCRT-ZS SLOPE TOP	-	SS40
ISLANDAIRE AD	-	SSCM
ED	-	SSEA
JK	-	SSJK
KF	-	SSKK
NE	-	SSNS
RK	-	SSK
RM	-	SSZ
RT	-	SSCT
16	-	SS16
45	-	SS45
MCQUAY EA, ES, RS	-	SSEA
N, NM, PDNS	-	SSNS
PNES	-	SS16
K, EK, RK	-	SSKK
TYPE 41	-	SS41
REMINGTON EA, ES, RS	-	SSEA
K, EK, RK	-	SSKK
RETROARIE RC/RH 20	-	SSZ
RH22	-	SSK
RH35	-	SSEA
RH60	-	SSKK
RH90	-	SSCM
SINGER K	-	SSKK
45	-	SS45
WM	-	SSWSHP
SLANT FIN JK	-	SSJK
TPI	-	SSZ
WEIL-MCLAIN 700SERIES	-	SSCM
WATER FURNANCE CC	-	SSWSHP
ZONEAIRE	-	SSZ

## STANDARD FEATURES INCLUDED WITH EACH CHASSIS

- Simon-Aire digital touch pad control.
- Simon-Aire exclusive touch pad models control can be removed from the chassis and mounted as two wire wall thermostat.
- Manual modes and auto heating/cooling changeover. (touch pad models only)
- Manual two speed modes and auto fan speed ( touch pad models only)
- Hidden internal set limits. (touch pad models only)
- Optional wireless thermostat interface and option.
- Central system capable via 24V PCB
- "Wall thermostat / touch pad" can be mounted in any "hidden" location to control room.
- Hi efficiency 410a compressors.
- External compressor overload protection.
- 1.5mm bulkhead and base pan sheet metal. (most models)
- All metal components are deposition coated galvanized steel.
- "Lifetime" metal deposition coated condensate drain pan.
- Dual flow balanced 1" condensate drain lines.
- Aluminum condenser fan blade hi speed balanced for long life.
- Rifled copper refrigerant tubing.
- "Hydro vent" bonded coating on evaporator coils, protects the coils and eliminates adhesion of condensate.
- Washable nylon mesh air filter with stainless steel frame.
- Optional MERV 6 air filter with aluminum frame
- Integral compressor freeze thermostat protection.
- Molex quick disconnects for the evaporator fan assy. Makes maintenance and replacement a quick swap out.
- Bulkhead exterior is lined with continuous strand fiberglass insulation.
- Bulkhead interior is lined with non absorbent closed cell thermal and sound insulation.
- Air surfaces are lined with closed cell PVC insulation.
- Optional fresh air inlet on models can be motorized or manual. Fresh air doors are insulated and internally gasketed to the outside air.
- PVC (on metal to metal assemblies) gap insulation insures vibration and draft free operation.
- LCDI: ground fault power cord protection and disconnect.
- UL /CUL Listed
- NY MEA approved
- Exclusive Simon-Aire warranty (2 years all parts and labor) (additional 4 years on the compressor part) (call for national warranty coverage)
- Generically available non-OEM motors, fan blades and compressors. For long service insurance and comfort of purchase.
- ETL Listed
- All models comply with federal standards.



MODEL  
**SSNY/SSCT**



EXACT REPLACEMENT  
FOR THE  
42" ICECAP RSCT  
ISLANDAIRE EZ  
SERIES RT, NY

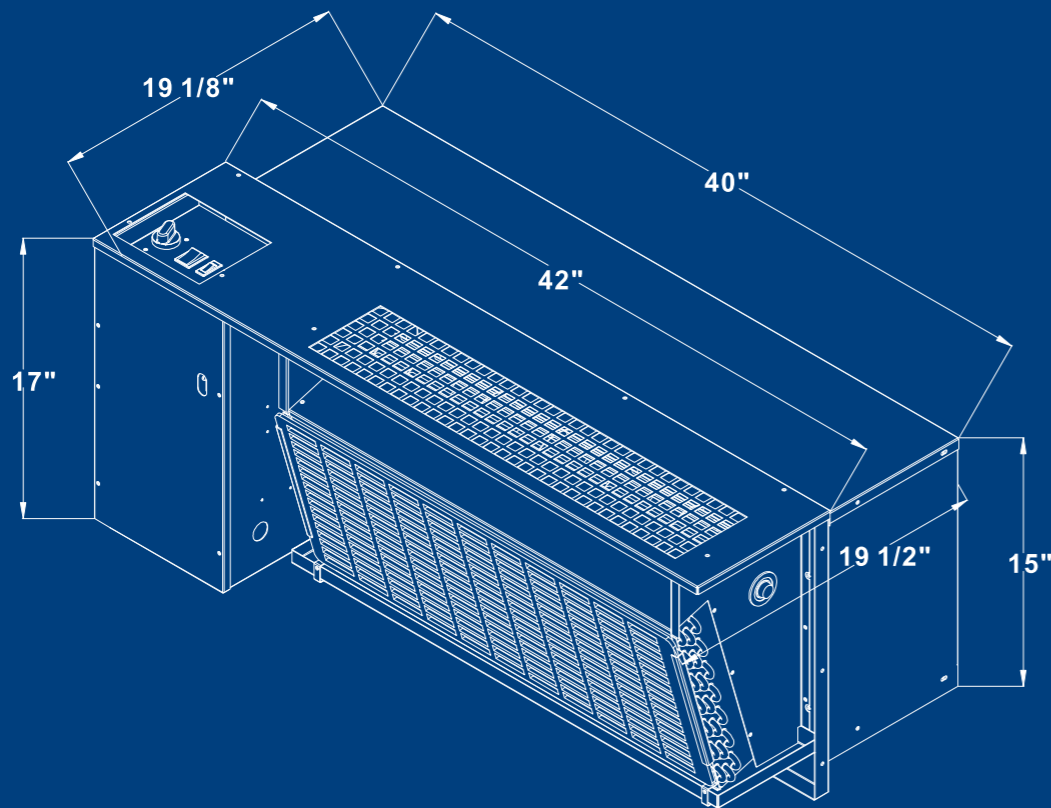

**410A**  
REFRIGERANT



Line Voltage	Maximum Amperage	Wall Socket Configuration	Receptacle Number	Electrical Heat Options
115	16	⊕	NEMA5-20R	3.0-3.5
208/230	12	⊖	NEMA6-15R	3.0-3.5
208/230	16	⊕	NEMA6-20R	3.0-3.5
208/230	24	⊖	NEMA6-30R	3.0-3.5
270	16	⊖	NEMA7-20R	3.0-3.5

- ANALOG CONTROL AND MAIN THERMOSTAT (OPTIONAL)  
PTC CERAMIC ELECTRIC HEAT OPTION AVAILABLE-CONSULT FACTORY

MODEL	SSNY509H-TP	SSNY809H-TP	SSNY513H-TP	SSCT816H-TP
COOLING CAPACITY (BTU/h)	9500	9500	12900	16000
HEATING CAPACITY HOT WATER (BTU/h)	16500/15100	16500/15100	16500/15100	16500/15100
VOLTAGE (V)	115V	208V	115V	208V
WATTS (W)	840	850	1280	1690
AIR FLOW (CFM)	390/330	390/330	390/330	390/300
AMPS (A)	7.3	4.1	11.1	8.2
EER	11.31	11.18	10.01	9.45
CHASSIS DIMENSIONS (in.)	40x 19 1/2 x 15	40x 19 1/2 x 15	40x 19 1/2 x 15	40x 19 1/2 x 15
SHIPPING BOX DIMENSION (in.)	46 3/4 X 23 3/4 X 20 1/2	46 3/4 X 23 3/4 X 20 1/2	46 3/4 X 23 3/4 X 20 1/2	46 3/4 X 23 3/4 X 20 1/2
WEIGHT (LBS)	155	155	158	158
LOADING (40'20')	120/52	120/52	120/52	120/52
HEATING CAPACITY STM (BTU/h)	18700/16500	18700/16500	18700/16500	18700/16500

- Important Note: Due to the ongoing development, the performance, specifications, components, and design is subject to change without notice. Please contact factory.  
All chassis are Tested and Rated in Accordance with ARI 310/380 and UL Standard 484.  
All "replacement" PTAC chassis are UL Listed for safety and ETL tested.

MODEL  
**SSK**

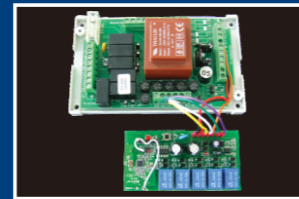

AN EXACT CHASSIS REPLACEMENT  
FOR THE 36"  
ICE-CAP RSK, ISLANDAIRE RK  
AND RETROAIRE Rc22

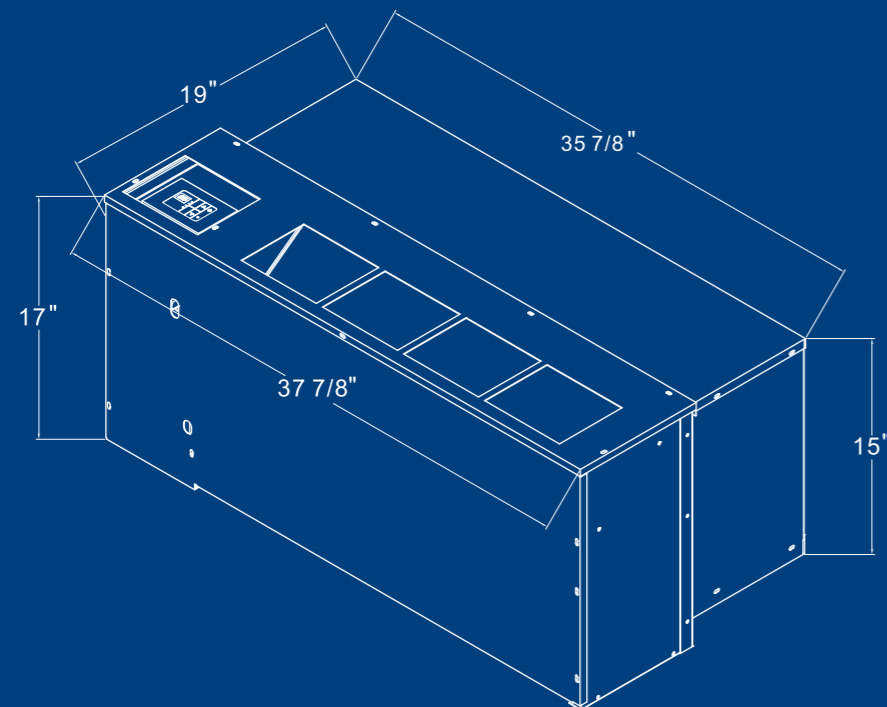

**410A**  
REFRIGERANT



Line Voltage	Maximum Amperage	Wall Socket Configuration	Receptacle Number	Electrical Heat Options
115	16	⊕	NEMA5-20R	3.0-3.5
208/230	12	⊖	NEMA6-15R	3.0-3.5
208/230	16	⊕	NEMA6-20R	3.0-3.5
208/230	24	⊖	NEMA6-30R	3.0-3.5
270	16	⊖	NEMA7-20R	3.0-3.5

- ANALOG CONTROL AND MAIN THERMOSTAT (OPTIONAL)  
PTC CERAMIC ELECTRIC HEAT OPTION AVAILABLE-CONSULT FACTORY

MODEL	SSK509H-TP	SSK809H-TP	SSK513H-TP	SSK813H-TP	SSK818H-TP
FAN SPEED	HIGH/LOW	HIGH/LOW	HIGH/LOW	HIGH/LOW	HIGH/LOW
COOLING CAPACITY (BTU/h)	9200	8700	11400	12200	16400
HEATING CAPACITY HOT WATER (BTU/h)	16500/15100	16500/15100	16500/15100	16500/15100	19400/18100
VOLTAGE (V)	115V	208V	115V	208V	208V
WATTS (W)	976	963	1307	1427	2052
AIR FLOW (CFM)	390/300	490/335	385/300	480/300	480/335
AMPS (A)	8.7	4.6	11.6	6.9	9.9
EER	9.43	9.03	8.72	8.55	8.0
R410 CHARGE OZ.	25.4	26.5	28.2	28.2	38.8
CHASSIS DIMENSIONS (in.)	35 7/8X19X15	35 7/8X19X15	35 7/8X19X15	35 7/8X19X15	35 7/8X19X15
SHIPPING BOX DIMENSION (in.)	42 3/4 X 23 3/4 X 20 1/2	42 3/4 X 23 3/4 X 20 1/2	42 3/4 X 23 3/4 X 20 1/2	42 3/4 X 23 3/4 X 20 1/2	42 3/4 X 23 3/4 X 20 1/2
WEIGHT (LBS)	139	139	146	146	156
LOADING (40'20')	160/72	160/72	160/72	160/72	160/72
HEATING CAPACITY STM (BTU/h)	18700/16500	18700/16500	18700/16500	18700/16500	20000/19400

- Important Note: Due to the ongoing development, the performance, specifications, components, and design is subject to change without notice. Please contact factory.  
All chassis are Tested and Rated in Accordance with ARI 310/380 and UL Standard 484.  
All "replacement" PTAC chassis are UL Listed for safety and ETL tested.

MODEL  
**SS45**

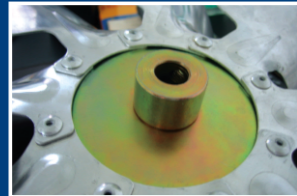

EXACT REPLACEMENT FOR THE  
AMERICAN STANDARD CARTERET45  
REMINGTON45  
SINGER 45

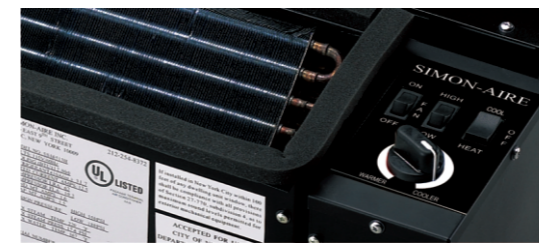
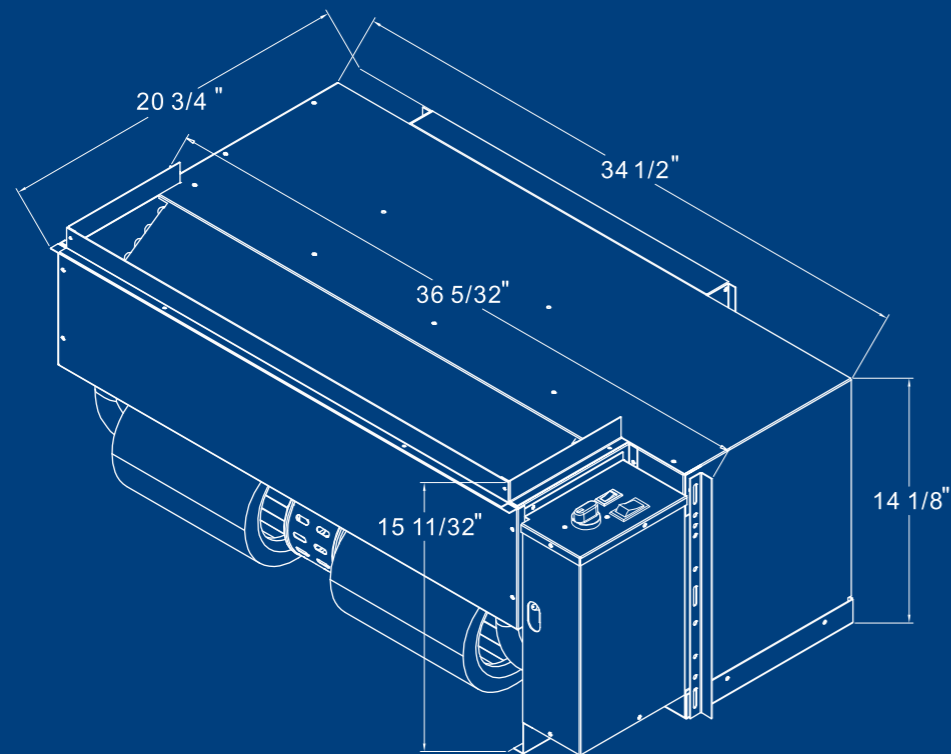

Line Voltage	Maximum Amparage	Wall Socket Configuration	Receptacle Number	Electrical Heat Options
115	16	⊕	NEMA5-20R	3.0-3.5
208/230	12	⊖	NEMA6-15R	3.0-3.5
208/230	16	⊕	NEMA6-20R	3.0-3.5
208/230	24	⊖	NEMA6-30R	3.0-3.5
270	16	⊖	NEMA7-20R	3.0-3.5

- ANALOG CONTROL AND MAIN THERMOSTAT (OPTIONAL)  
PTC CERAMIC ELECTRIC HEAT OPTION AVAILABLE-CONSULT FACTORY

MODEL	SS45509H	SS45809H	SS45513H	SS45813H	SS45818H
FAN SPEED	HIGH/LOW	HIGH/LOW	HIGH/LOW	HIGH/LOW	HIGH/LOW
COOLING CAPACITY (BTU/h)	9200	8700	11400	12200	16400
HEATING CAPACITY HOT WATER (BTU/h)	16500/15100	16500/15100	16500/15100	16500/15100	19400/18100
VOLTAGE (V)	115V	208V	115V	208V	208V
WATTS (W)	976	963	1307	1427	2052
AIR FLOW (CFM)	375/290	480/330	375/290	470/320	480/335
AMPS (A)	8.7	4.6	11.6	6.9	9.9
EER	9.43	9.03	8.72	8.55	8.0
R410 CHARGE OZ.	25.4	26.5	30	30	42.3
CHASSIS DIMENSIONS (in.)	34 1/2 X 20 3/4 X 14 1/8	34 1/2 X 20 3/4 X 14 1/8	34 1/2 X 20 3/4 X 14 1/8	34 1/2 X 20 3/4 X 14 1/8	34 1/2 X 20 3/4 X 14 1/8
SHIPPING BOX DIMENSION (in.)	39 1/2 X 24 1/4 X 19 3/4	39 1/2 X 24 1/4 X 19 3/4	39 1/2 X 24 1/4 X 19 3/4	39 1/2 X 24 1/4 X 19 3/4	39 1/2 X 24 1/4 X 19 3/4
WEIGHT (LBS)	125	125	136	136	152
LOADING (40'20')	160/72	160/72	160/72	160/72	160/72
HEATING CAPACITY STM (BTU/h)	18700/16500	18700/16500	18700/16500	18700/16500	20000/19400

- Important Note: Due to the ongoing development, the performance, specifications, components, and design is subject to change without notice. Please contact factory. All chassis are Tested and Rated in Accordance with ARI 310/380 and UL Standard 484. All "replacement" PTAC ch

MODEL

# SS16



EXACT REPLACEMENT FOR THE AMERICAN STANDARD SERIES 16 RETROAIRE RC-10, AAF ENERSAVER ISLANDAIRE EZ SERIES 16, ENH, WY AND YY.

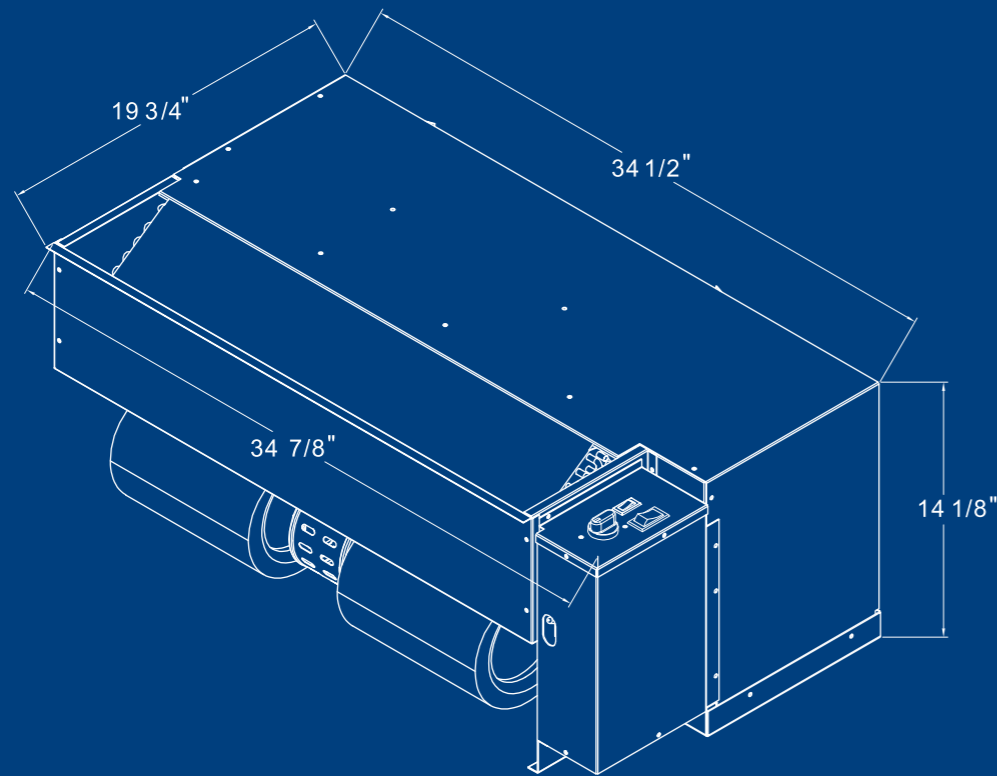

**410A**  
REFRIGERANT



Line Voltage	Maximum Amparage	Wall Socket Configuration	Receptacle Number	Electrical Heat Options
115	16	⊕	NEMA5-20R	3.0-3.5
208/230	12	⊖	NEMA6-15R	3.0-3.5
208/230	16	⊕	NEMA6-20R	3.0-3.5
208/230	24	⊖	NEMA6-30R	3.0-3.5
270	16	⊖	NEMA7-20R	3.0-3.5

- ANALOG CONTROL AND MAIN THERMOSTAT (OPTIONAL)  
PTC CERAMIC ELECTRIC HEAT OPTION AVAILABLE-CONSULT FACTORY

MODEL	SS16509H	SS16809H	SS16513H	SS16813H	SS16818H
FAN SPEED	HIGH/LOW	HIGH/LOW	HIGH/LOW	HIGH/LOW	HIGH/LOW
COOLING CAPACITY (BTU/h)	9200	8700	11400	12200	16400
HEATING CAPACITY HOT WATER (BTU/h)	16500/15100	16500/15100	16500/15100	16500/15100	19400/18100
VOLTAGE (V)	115V	208V	115V	208V	208V
WATTS (W)	976	963	1307	1427	2052
AIR FLOW (CFM)	375/290	480/330	375/290	470/320	480/335
AMPS (A)	8.7	4.6	11.6	6.9	9.9
EER	9.43	9.03	8.72	8.55	8.0
R410 CHARGE OZ.	25.4	26.5	30	30	42.3
CHASSIS DIMENSIONS (in.)	34 1/2 X 19 3/4 X 14 1/8	34 1/2 X 19 3/4 X 14 1/8	34 1/2 X 19 3/4 X 14 1/8	34 1/2 X 19 3/4 X 14 1/8	34 1/2 X 19 3/4 X 14 1/8
SHIPPING BOX DIMENSION (in.)	39 1/4 X 23 1/4 X 18 1/2	39 1/4 X 23 1/4 X 18 1/2	39 1/4 X 23 1/4 X 18 1/2	39 1/4 X 23 1/4 X 18 1/2	39 1/4 X 23 1/4 X 18 1/2
WEIGHT (LBS)	125	125	136	136	152
LOADING (40'20')	160/72	160/72	160/72	160/72	160/72
HEATING CAPACITY STM (BTU/h)	18700/16500	18700/16500	18700/16500	18700/16500	20000/19400

- Important Note: Due to the ongoing development, the performance, specifications, components, and design is subject to change without notice. Please contact factory. All chassis are Tested and Rated in Accordance with ARI 310/380 and UL Standard 484. All "replacement" PTAC chassis are UL Listed for safety and ETL tested.



MODEL  
**SSCM**

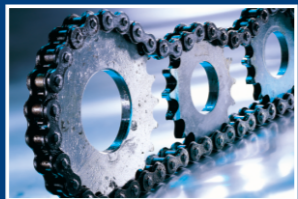

EXACT CHASSIS REPLACEMENT  
FOR THE:  
FRIEDRICH CLIMATE MASTER  
WEIL-MCLAIN SERIES 700AD, 702, 703 AND 704  
ISLANDAIRE EZ SERIES AD AND CM,  
ICECAP RSCM

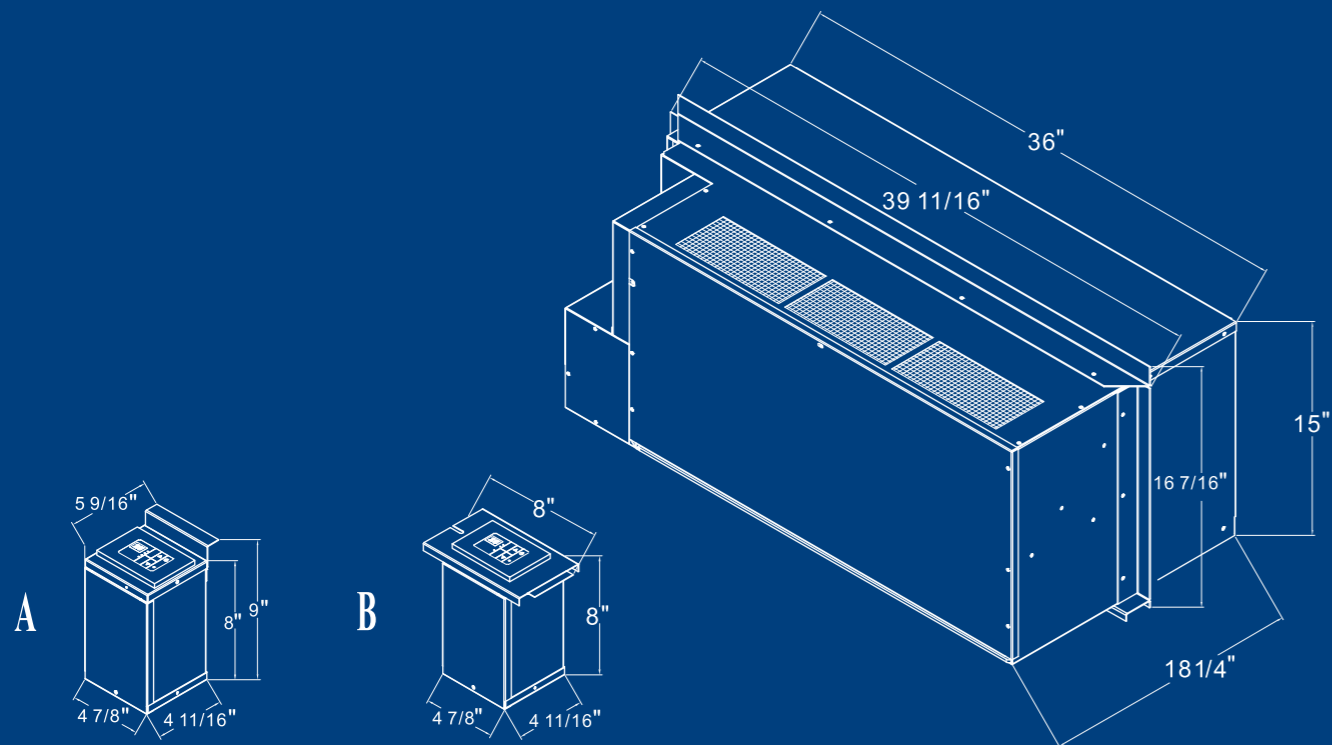

**410A**  
REFRIGERANT



Line Voltage	Maximum Amperage	Wall Socket Configuration	Receptacle Number	Electrical Heat Options
115	16	⊕	NEMA5-20R	3.0-3.5
208/230	12	⊖	NEMA6-15R	3.0-3.5
208/230	16	⊕	NEMA6-20R	3.0-3.5
208/230	24	⊖	NEMA6-30R	3.0-3.5
270	16	⊖	NEMA7-20R	3.0-3.5

• PTC CERAMIC ELECTRIC HEAT OPTION AVAILABLE-CONSULT FACTORY

MODEL	SSCM509H-TP	SSCM809H-TP	SSCM513H-TP	SSCM813H-TP	SSCM818H-TP
FAN SPEED	HIGH/LOW	HIGH/LOW	HIGH/LOW	HIGH/LOW	HIGH/LOW
COOLING CAPACITY (BTU/h)	9200	8700	11400	12200	16400
HEATING CAPACITY HOT WATER (BTU/h)	16500/15100	16500/15100	16500/15100	16500/15100	19400/18100
VOLTAGE (V)	115V	208V	115V	208V	208V
WATTS (W)	976	963	1307	1427	2052
AIR FLOW (CFM)	375/290	480/330	375/290	470/320	480/335
AMPS (A)	8.7	4.6	11.6	6.9	9.9
EER	9.43	9.03	8.72	8.55	8.0
R410 CHARGE OZ.	25.4	26.5	28.9	28.9	38.8
CHASSIS DIMENSIONS (in.)	36 X 18 1/4 X 15	36 X 18 1/4 X 15	36 X 18 1/4 X 15	36 X 18 1/4 X 15	36 X 18 1/4 X 15
SHIPPING BOX DIMENSION (in.)	42 1/2 X 22 1/2 X 19 3/4	42 1/2 X 22 1/2 X 19 3/4	42 1/2 X 22 1/2 X 19 3/4	42 1/2 X 22 1/2 X 19 3/4	42 1/2 X 22 1/2 X 19 3/4
WEIGHT (LBS)	134	134	138	138	152
LOADING (40'20')	160/72	160/72	160/72	160/72	160/72
HEATING CAPACITY STM (BTU/h)	18700/16500	18700/16500	18700/16500	18700/16500	20000/19400

• Important Note: Due to the ongoing development, the performance, specifications, components, and design is subject to change without notice. Please contact factory.  
All chassis are Tested and Rated in Accordance with ARI 310/380 and UL Standard 484.  
All "replacement" PTAC ch

MODEL

# SSZ



EXACT CHASSIS REPLACEMENT  
FOR THE:  
EMBASSY WEATHER TWIN  
KAPSIS COOL HEAT  
TPI RA-MATIC  
ZONEAIRE RM & SC SERIES  
ICECAP RSZ  
ISLANDAIRE EZ SERIES RM

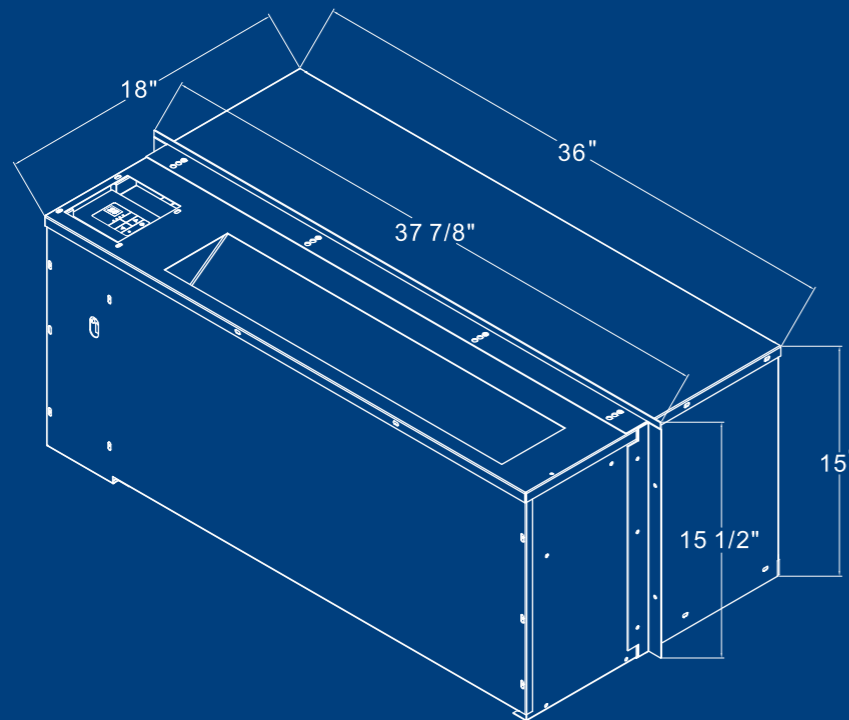

SIMON-AIRE INC.  
**SSZ**



**410A**  
REFRIGERANT



Line Voltage	Maximum Amperage	Wall Socket Configuration	Receptacle Number	Electrical Heat Options
115	16	⊕	NEMA5-20R	3.0-3.5
208/230	12	⊖	NEMA6-15R	3.0-3.5
208/230	16	⊕	NEMA6-20R	3.0-3.5
208/230	24	⊖	NEMA6-30R	3.0-3.5
270	16	⊖	NEMA7-20R	3.0-3.5

- ANALOG CONTROL AND MAIN THERMOSTAT (OPTIONAL)  
PTC CERAMIC ELECTRIC HEAT OPTION AVAILABLE-CONSULT FACTORY

MODEL	SSZ509H-TP	SSZ809H-TP	SSZ513H-TP	SSZ813H-TP	SSZ818H-TP
FAN SPEED	HIGH/LOW	HIGH/LOW	HIGH/LOW	HIGH/LOW	HIGH/LOW
COOLING CAPACITY (BTU/h)	9200	8700	11400	12200	16400
HEATING CAPACITY HOT WATER (BTU/h)	16500/15100	16500/15100	16500/15100	16500/15100	16500/15100
VOLTAGE (V)	115V	208V	115V	208V	208V
WATTS (W)	976	963	1307	1427	2052
AIR FLOW (CFM)	375/290	450/300	390/320	450/300	450/300
AMPS (A)	8.7	4.6	11.6	6.9	9.9
EER	9.43	9.03	8.72	8.55	8.0
R410 CHARGE OZ.	25.4	26.5	28.2	28.2	38.8
CHASSIS DIMENSIONS (in.)	37 7/8x18x15 1/2				
SHIPPING BOX DIMENSION (in.)	40 1/8x23 1/4x18				
WEIGHT (LBS)	134	134	138	152	152
LOADING (40'20')	160/72	160/72	160/72	160/72	160/72
HEATING CAPACITY STM (BTU/h)	18700/16500	18700/16500	18700/16500	18700/16500	20000/19400

- Important Note: Due to the ongoing development, the performance, specifications, components, and design is subject to change without notice. Please contact factory.  
All chassis are Tested and Rated in Accordance with ARI 310/380 and UL Standard 484.  
All "replacement" PTAC chassis are UL Listed for safety and ETL tested.

# MODEL SSZHP



EXACT CHASSIS REPLACEMENT  
FOR THE:  
EMBASSY WEATHER TWIN  
KAPSIS COOL HEAT  
TPI RA-MATIC  
ZONEAIRE RM & SC SERIES  
ICECAP RSZ  
ISLANDAIRE EZ SERIES RM

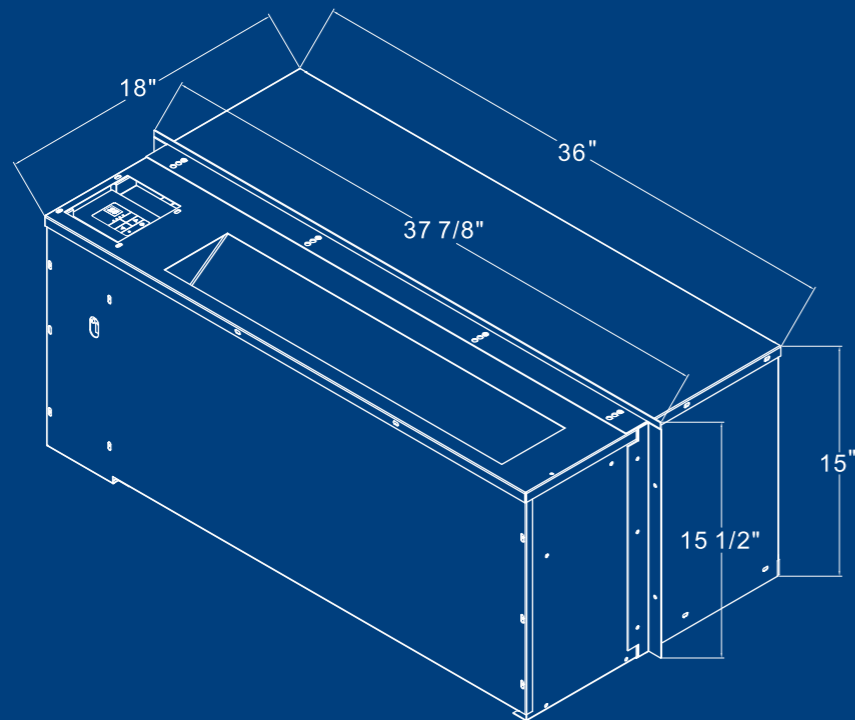

SIMON-AIRE INC.  
**SSZHP**



**410A**  
REFRIGERANT



Line Voltage	Maximum Amperage	Wall Socket Configuration	Receptacle Number	Electrical Heat Options
115	16	⊕	NEMA5-20R	3.0-3.5
208/230	12	⊖	NEMA6-15R	3.0-3.5
208/230	16	⊕	NEMA6-20R	3.0-3.5
208/230	24	⊖	NEMA6-30R	3.0-3.5
270	16	⊖	NEMA7-20R	3.0-3.5

- ANALOG CONTROL AND MAIN THERMOSTAT (OPTIONAL)  
PTC CERAMIC ELECTRIC HEAT OPTION AVAILABLE-CONSULT FACTORY

MODEL	SSZ809HP-E3.5-RS	SSZ813HP-E3.5-RS	SSZ816HP-E3.5-RS	SSZ818HP-E3.5-RS
FAN SPEED	HIGH/LOW	HIGH/LOW	HIGH/LOW	HIGH/LOW
COOLING CAPACITY(BTU/h)	9000/8600	12400/12040	14200/13570	16380/15650
HEATING CAPACITY (BTU/h)	9100	11900	14400	16200
ELECTRIC HEATER(KW)	3.5	3.5	3.5	3.5
VOLTAGE(V)	208	208	208	208
WATTS C/H(W)	950/915	1432/1287	1736/1507	2040/1850
AIR FLOW(CFM)	330/310	328/290	330/310	330/310
AMPS C/H(A)	4.64/4.41	7.0/6.2	8.4/7.5	9.87/9.21
EER/COP	9.47/2.92	8.66/2.71	8.18/2.8	8.03/2.57
R410 CHARGE OZ.	26.5	44.1	38.4	42.3
CHASSIS DIMENSIONS(in.)	37 7/8x18x15 1/2			
SHIPPING BOX DIMENSION(in.)	40 1/8x23 1/4x18			
WEIGHT(LBS)	137	150	150	154
LOADING(40'/20')	160/72	160/72	160/72	160/72

- Important Note: Due to the ongoing development, the performance, specifications, components, and design is subject to change without notice. Please contact factory.  
All chassis are Tested and Rated in Accordance with ARI 310/380 and UL Standard 484.  
All "replacement" PTAC chassis are UL Listed for safety and ETL tested.

MODEL  
**SSKK-1P**

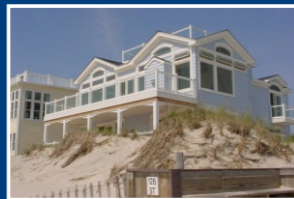

EXACT REPLACEMENT  
FOR THE  
MCQUAY K  
REMINGTON K  
SINGER K  
ISLANDAIRE KF  
RETROAIRE RC 60

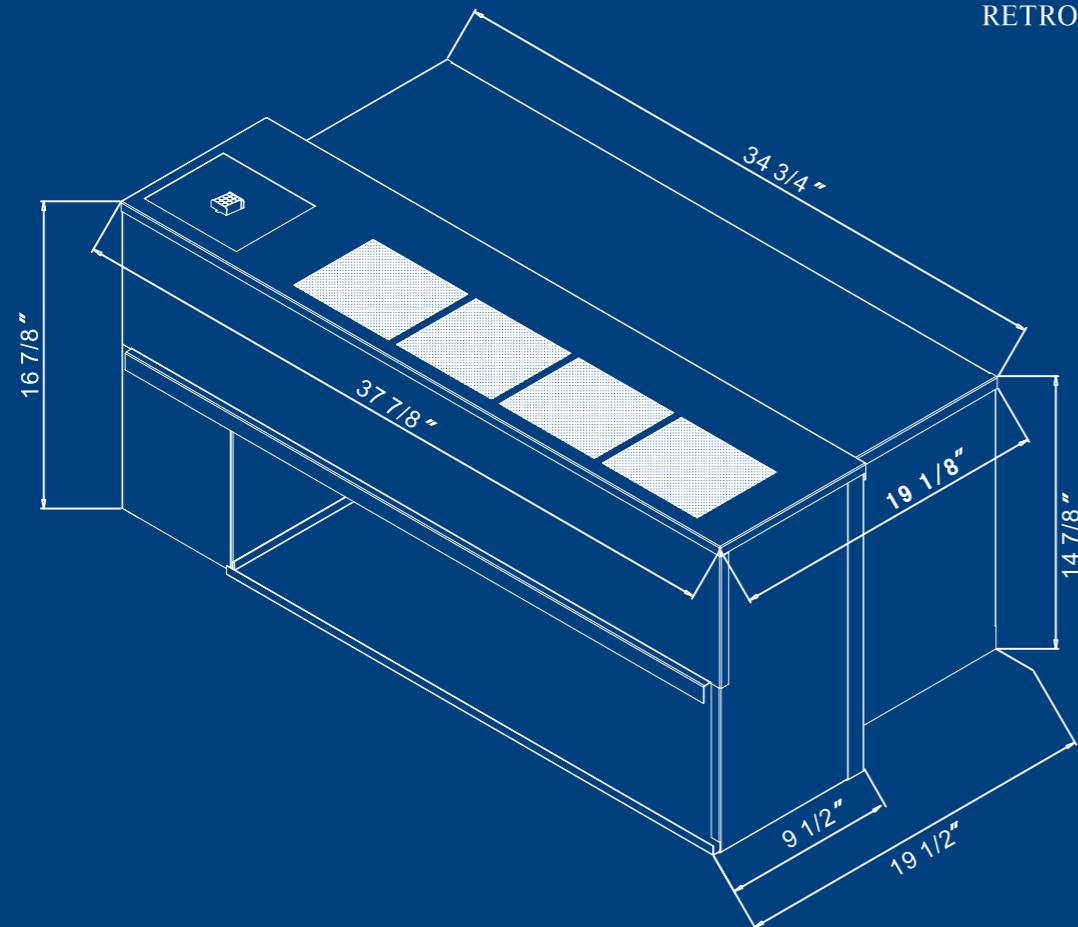

**410A**  
REFRIGERANT



Line Voltage	Maximum Amperage	Wall Socket Configuration	Receptacle Number	Electrical Heat Options
115	16	⊕	NEMA5-20R	3.0-3.5
208/230	12	⊖	NEMA6-15R	3.0-3.5
208/230	16	⊕	NEMA6-20R	3.0-3.5
208/230	24	⊖	NEMA6-30R	3.0-3.5
270	16	⊖	NEMA7-20R	3.0-3.5

- ANALOG CONTROL AND MAIN THERMOSTAT (OPTIONAL)  
PTC CERAMIC ELECTRIC HEAT OPTION AVAILABLE-CONSULT FACTORY

MODEL	SSKK509H-1PTP	SSKK809H-1PTP	SSKK513H-1PTP	SSKK813H-1PTP	SSKK818H-1PTP
FAN SPEED	HIGH/LOW	HIGH/LOW	HIGH/LOW	HIGH/LOW	HIGH/LOW
COOLING CAPACITY (BTU/h)	9200	8700	11400	12200	16400
HEATING CAPACITY HOT WATER (BTU/h)	16500/15100	16500/15100	16500/15100	16500/15100	19400/18100
VOLTAGE (V)	115V	208V	115V	208V	208V
WATTS (W)	976	963	1307	1427	2052
AIR FLOW (CFM)	375/290	480/330	390/290	470/320	480/335
AMPS (A)	8.7	4.6	11.6	6.9	9.9
EER	9.43	9.03	8.72	8.55	8.0
R410 CHARGE (OZ.)	25.4	26.5	28.2	28.2	38.8
CHASSIS DIMENSIONS (in.)	34 3/4 X 19 1/2 X 14 7/8	34 3/4 X 19 1/2 X 14 7/8	34 3/4 X 19 1/2 X 14 7/8	34 3/4 X 19 1/2 X 14 7/8	34 3/4 X 19 1/2 X 14 7/8
SHIPPING BOX DIMENSION (in.)	45 3/4 X 23 3/4 X 20 1/2	45 3/4 X 23 3/4 X 20 1/2	45 3/4 X 23 3/4 X 20 1/2	45 3/4 X 23 3/4 X 20 1/2	45 3/4 X 23 3/4 X 20 1/2
WEIGHT (LBS)	139	139	146	146	152
LOADING (40'20')	160/72	160/72	160/72	160/72	160/72
HEATING CAPACITY STM (BTU/h)	18700/16500	18700/16500	18700/16500	18700/16500	20000/19400

- Important Note: Due to the ongoing development, the performance, specifications, components, and design is subject to change without notice. Please contact factory.  
All chassis are Tested and Rated in Accordance with ARI 310/380 and UL Standard 484.  
All "replacement" PTAC chassis are UL Listed for safety and ETL tested.

MODEL

# SSKK-3P



EXACT REPLACEMENT  
FOR THE  
MCQUAY K  
REMINGTON K  
SINGER K  
ISLANDAIRE KF  
RETRONAIRE RC60

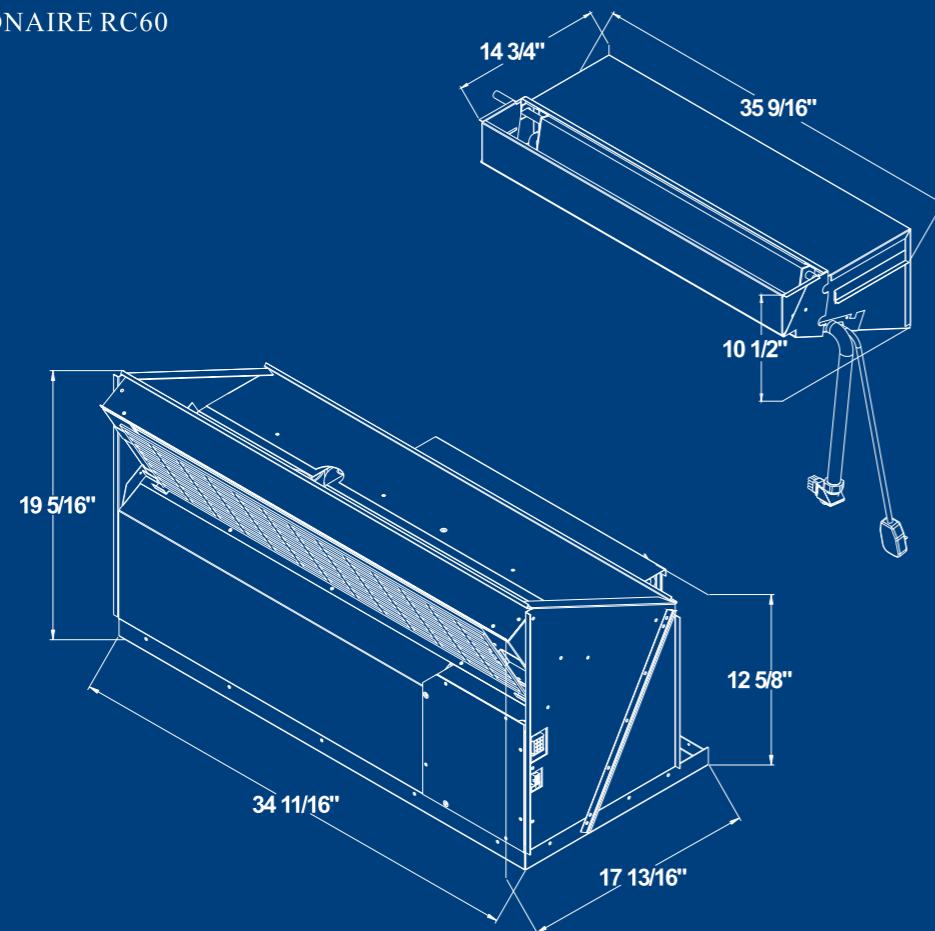

Line Voltage	Maximum Amperage	Wall Socket Configuration	Receptacle Number	Electrical Heat Options
115	16	⊕	NEMA5-20R	3.0-3.5
208/230	12	⊖	NEMA6-15R	3.0-3.5
208/230	16	⊕	NEMA6-20R	3.0-3.5
208/230	24	⊖	NEMA6-30R	3.0-3.5
270	16	⊖	NEMA7-20R	3.0-3.5

- PTC CERAMIC ELECTRIC HEAT OPTION AVAILABLE-CONSULT FACTORY

MODEL	SSKK809H-3PRS	SSKK513H-3PRS	SSKK813H-3PRS	SSKK815H-3PRS
FAN SPEED	HIGH/LOW	HIGH/LOW	HIGH/LOW	HIGH/LOW
COOLING CAPACITY (BTU/h)	8900	11800	12000	14600
ELECTRIC HEATING CAPACITY (W)(OPTION)	3.2	3.2	3.2	3.2
HEATING CAPACITY HOT WATER (BTU/h)	16500/15100	16500/15100	16500/15100	16500/15100
VOLTAGE (V)	208	115	208	208
WATTS (W)	920	1355	1410	1770
AIR FLOW (CFM)	360/310	350/270	360/310	360/310
AMPS (A)	4.4	11.8	6.8	8.2
EER	9.68	8.70	8.54	8.25
CHASSIS DIMENSIONS (in.)	34 11/16X17 13/16X19 5/16	34 11/16X17 13/16X19 5/16	34 11/16X17 13/16X19 5/16	34 11/16X17 13/16X19 5/16
SHIPPING BOX DIMENSION (in.)	42 1/8X20 7/8X22 3/4	42 1/8X20 7/8X22 3/4	42 1/8X20 7/8X22 3/4	42 1/8X20 7/8X22 3/4
BLOWER ASSY DIMENSION	35 9/16X10 1/2X 14 3/4	35 9/16X10 1/2X 14 3/4	35 9/16X10 1/2X 14 3/4	35 9/16X10 1/2X 14 3/4
SHIPPING BOX DIMENSION (in.)	42X14 1/2X18 1/8	42X14 1/2X18 1/8	42X14 1/2X18 1/8	42X14 1/2X18 1/8
WEIGHT (LBS)	115+57	117+57	117+57	123+57
LOADING (40'20')	116/88	116/88	116/88	116/88
HEATING CAPACITY STM (BTU/h)	18700/16500	18700/16500	18700/16500	18700/16500

- Important Note: Due to the ongoing development, the performance, specifications, components, and design is subject to change without notice. Please contact factory. All chassis are Tested and Rated in Accordance with ARI 310/380 and UL Standard 484. All "replacement" PTAC chassis are UL Listed for saf

MODEL  
**SS41-3P**



EXACT CHASSIS  
REPLACEMENT  
FOR THE  
MCQUAY TYPE 41

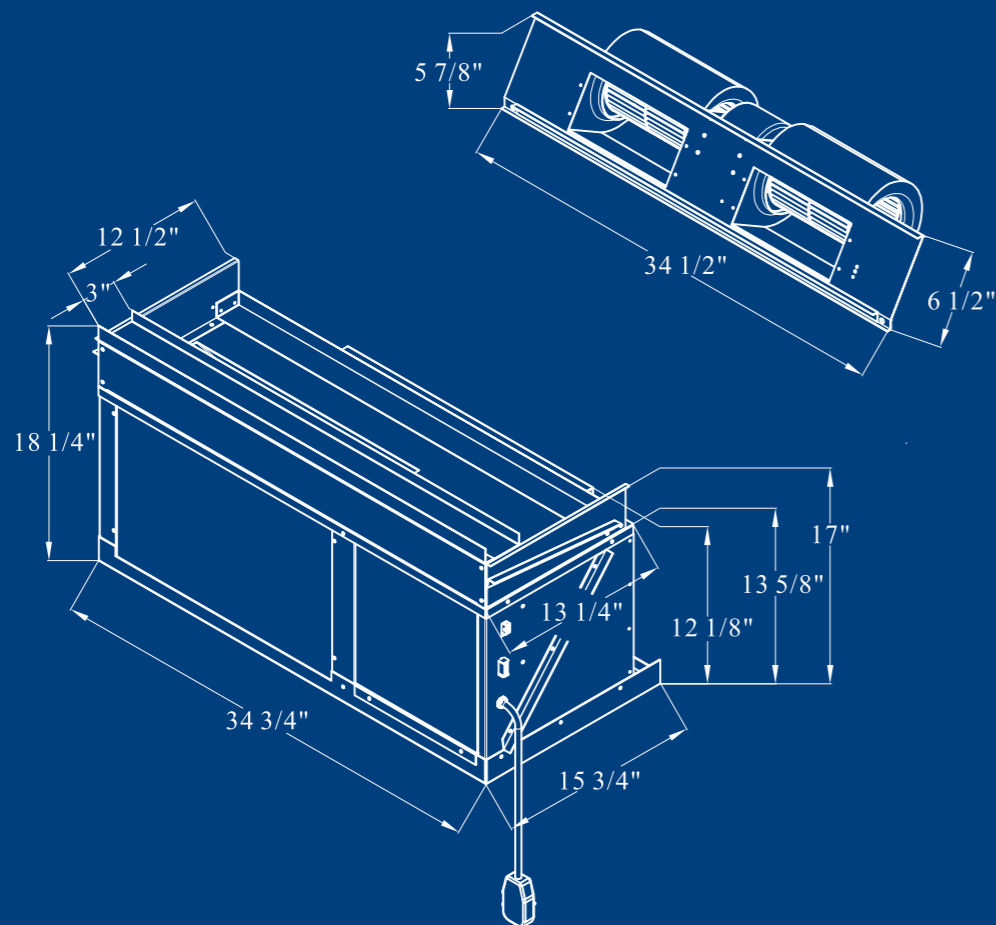

**410A**  
REFRIGERANT

Line Voltage	Maximum Amparage	Wall Socket Configuration	Receptacle Number	Electrical Heat Options
115	16	(I+)	NEMA5-20R	3.0-3.5
208/230	12	(-)	NEMA6-15R	3.0-3.5
208/230	16	(I+)	NEMA6-20R	3.0-3.5
208/230	24	(-)	NEMA6-30R	3.0-3.5
270	16	(-)	NEMA7-20R	3.0-3.5

• PTC CERAMIC ELECTRIC HEAT OPTION AVAILABLE-CONSULT FACTORY

MODEL	SS41809H-3PTP	SS41513H-3PTP	SS41813H-3PTP	SS41816H-3PTP
FAN SPEED	HIGH/LOW	HIGH/LOW	HIGH/LOW	HIGH/LOW
COOLING CAPACITY(BTU/h)	9000/8800	12100/11850	12000/11800	14300/14000
HEATING CAPACITY HOT WATER(BTU/h)	16500/15100	16500/15100	16500/15100	16500/15100
VOLTAGE(V)	208	115	208	208
WATTS(W)	924	1329	1340	1626
AIR FLOW(CFM)	355/325	342/314	360/330	367/335
AMPS(A)	4.44	11.56	6.47	7.90
EER	9.74	9.10	8.96	8.79
R410 CHARGE OZ.	26.5	30.5	30.5	37.6
CHASSIS DIMENSIONS(in.)	34 3/4"x15 3/4"x18 1/4"			
SHIPPING BOX DIMENSION(in.)	39 3/8"x19 3/8"x19 1/2"			
WEIGHT(LBS)	105	115	115	117
LOADING(40'/20')				
HEATING CAPACITY STM(BTU/h)	18700/16500	18700/16500	18700/16500	18700/16500

• Important Note: Due to the ongoing development, the performance, specifications, components, and design is subject to change without notice. Please contact factory. All chassis are Tested and Rated in Accordance with ARI 310/380 and UL Standard 484. All "replacement" PTAC chassis are UL Listed for saf

MODEL  
**SSAM40**



EXACT REPLACEMENT  
FOR THE  
AMERICAN  
STANDARD  
TYPE 40

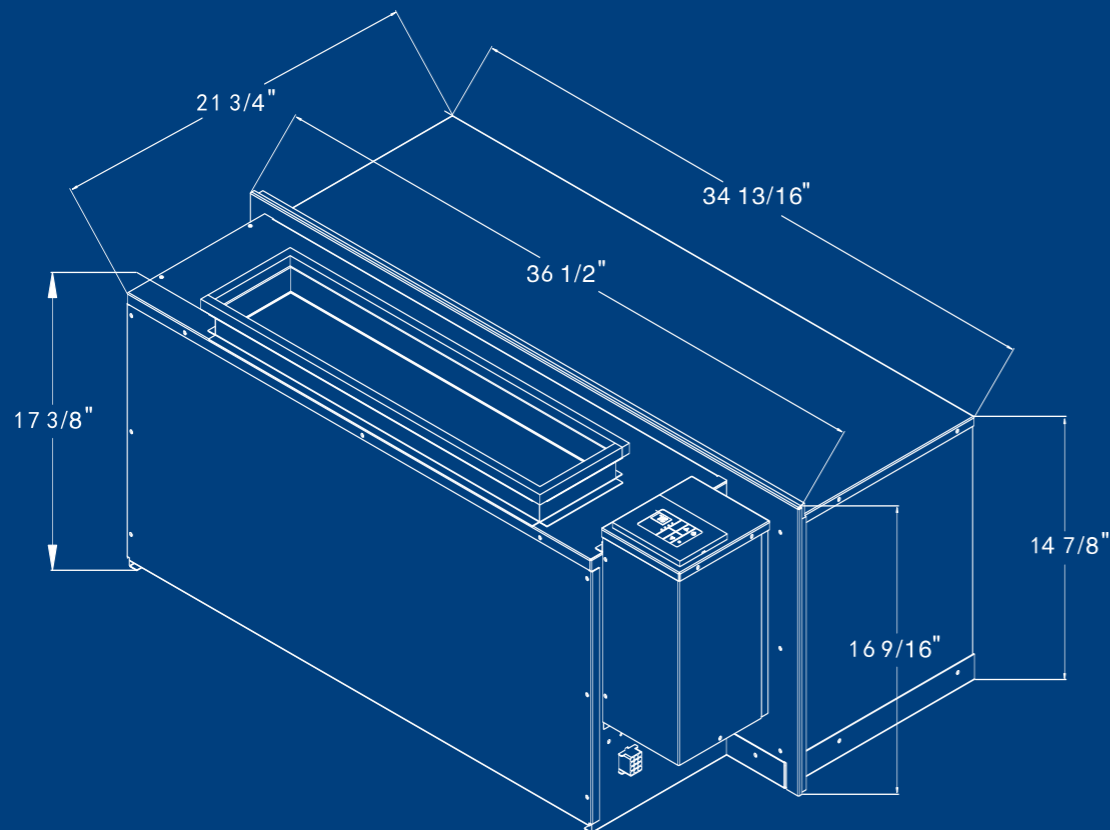

**410A**  
REFRIGERANT



Line Voltage	Maximum Amparage	Wall Socket Configuration	Receptacle Number	Electrical Heat Options
115	16	⊕	NEMA5-20R	3.0-3.5
208/230	12	⊖	NEMA6-15R	3.0-3.5
208/230	16	⊕	NEMA6-20R	3.0-3.5
208/230	24	⊖	NEMA6-30R	3.0-3.5
270	16	⊖	NEMA7-20R	3.0-3.5

- ANALOG CONTROL AND MAIN THERMOSTAT (OPTIONAL)  
PTC CERAMIC ELECTRIC HEAT OPTION AVAILABLE-CONSULT FACTORY

MODEL	SSAM40509H-TP	SSAM40809H-TP	SSAM40513H-TP	SSAM40813H-TP	SSAM40818H-TP
FAN SPEED	HIGH/LOW	HIGH/LOW	HIGH/LOW	HIGH/LOW	HIGH/LOW
COOLING CAPACITY (BTU/h)	9200	8700	11400	12200	16400
HEATING CAPACITY HOT WATER (BTU/h)	16500/15100	16500/15100	16500/15100	16500/15100	19400/18100
VOLTAGE (V)	115V	208V	115V	208V	208V
WATTS (W)	976	963	1307	1427	2050
AIR FLOW (CFM)	375/290	480/330	375/290	470/320	480/335
AMPS (A)	8.7	4.6	11.6	6.9	9.9
EER	9.43	9.03	8.72	8.55	8.0
R410 CHARGE OZ.	26.5	26.5	27.5	30	35.3
CHASSIS DIMENSIONS (in.)	34 13/16 X 21 3/4 X 14 7/8	34 13/16 X 21 3/4 X 14 7/8	34 13/16 X 21 3/4 X 14 7/8	34 13/16 X 21 3/4 X 14 7/8	34 13/16 X 21 3/4 X 14 7/8
SHIPPING BOX DIMENSION (in.)	42 1/2 X 21 X 23	42 1/2 X 21 X 23	42 1/2 X 21 X 23	42 1/2 X 21 X 23	42 1/2 X 21 X 23
WEIGHT (LBS)	139	139	146	146	152
LOADING (40'20')	123	123	123	123	123
HEATING CAPACITY STM (BTU/h)	18700/16500	18700/16500	18700/16500	18700/16500	18700/16500

- Important Note: Due to the ongoing development, the performance, specifications, components, and design is subject to change without notice. Please contact factory.  
All chassis are Tested and Rated in Accordance with ARI 310/380 and UL Standard 484.  
All "replacement" PTAC chassis are UL Listed for safety and ETL tested.

MODEL

# SSMX A/B

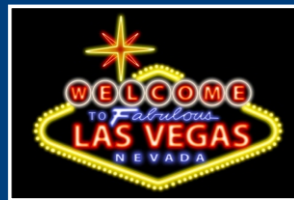
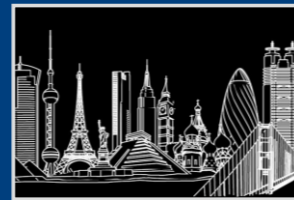
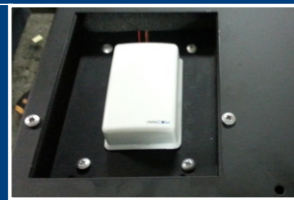

EXACT UPGRADE REPLACEMENT FOR THE:  
FEDDERS A AND B WALL SLEEVE CHASSIS,  
FRIEDRICH WALLMASTER CHASSIS &  
EXISTING 26 X 16 WALL SLEEVE APPLICATIONS.

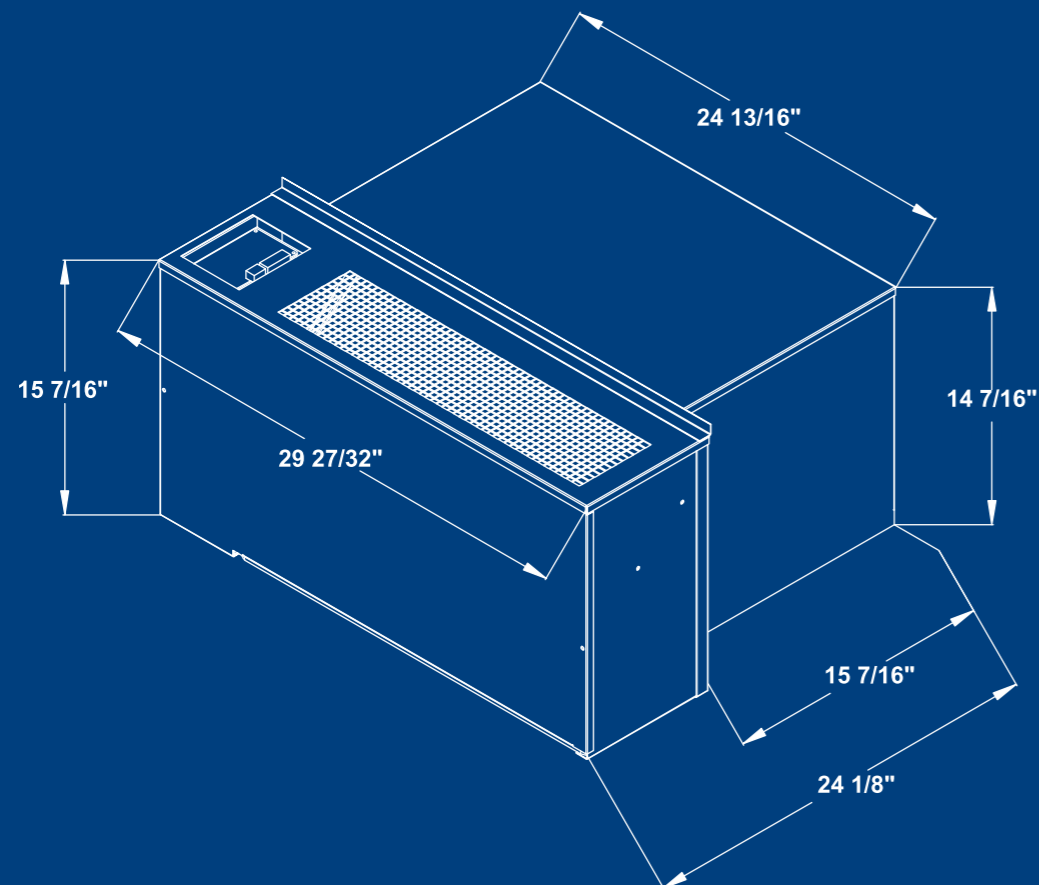

**410A**  
REFRIGERANT



Line Voltage	Maximum Ampage	Wall Socket Configuration	Receptacle Number	Electrical Heat Options
115	16	⊕	NEMA5-20R	3.0-3.5
208/230	12	⊖	NEMA6-15R	3.0-3.5
208/230	16	⊕	NEMA6-20R	3.0-3.5
208/230	24	⊖	NEMA6-30R	3.0-3.5
270	16	⊖	NEMA7-20R	3.0-3.5

- WIRELESS CONTROL IS AVAILABLE
- ANALOG CONTROL AND MAIN THERMOSTAT(OPTION)
- PTC CERAMIC ELECTRIC HEAT OPTION AVAILABLE-CONSULT FACTORY

MODEL	SSMX509H-TP	SSMX809H-TP	SSMX513H-TP	SSMX816H-TP
COOLING CAPACITY (BTU/h)	9000	9000	11800	11900
HEATING CAPACITY (W)(OPTION)	3.2	3.2	3.2	3.2
HEATING CAPACITY HOT WATER(BTU/h)	16500/15100	16500/15100	16500/15100	16500/15100
VOLTAGE (V)	115V	208V	115V	208V
WATTS (W)	970	950	1335	1330
AIR FLOW (CFM)	350/270	360/310	350/270	360/310
AMPS(A)	8.4	4.6	11.6	6.4
EER	9.28	9.47	8.84	8.94
CHASSIS DIMENSIONS (in.)	24 13/16X24 1/8X15 7/16	24 13/16X24 1/8X15 7/16	24 13/16X24 1/8X15 7/16	24 13/16X24 1/8X15 7/16
SHIPPING BOX DIMENSION (in.)	24 13/16x24 7/8x14 7/16	24 13/16x24 7/8x14 7/16	24 13/16x24 7/8x14 7/16	24 13/16x24 7/8x14 7/16
WEIGHT(LBS)	141	141	150	150
LOADING (40'20')	168/84	168/84	168/84	168/84
HEATING CAPACITY STM(BTU/h)	18700/16500	18700/16500	18700/16500	18700/16500

- Important Note: Due to the ongoing development, the performance, specifications, components, and design is subject to change without notice. Please contact factory. All chassis are Tested and Rated in Accordance with ARI 310/380 and UL Standard 484. All "replacement" PTAC chassis are UL Listed for safety and ETL tested.



MODEL  
**SSMX**



EXACT UPGRADE REPLACEMENT FOR THE:  
FEDDERS A AND B WALL SLEEVE CHASSIS,  
FRIEDRICH WALLMASTER CHASSIS &  
EXISTING 26 X 16 WALL SLEEVE APPLICATIONS.

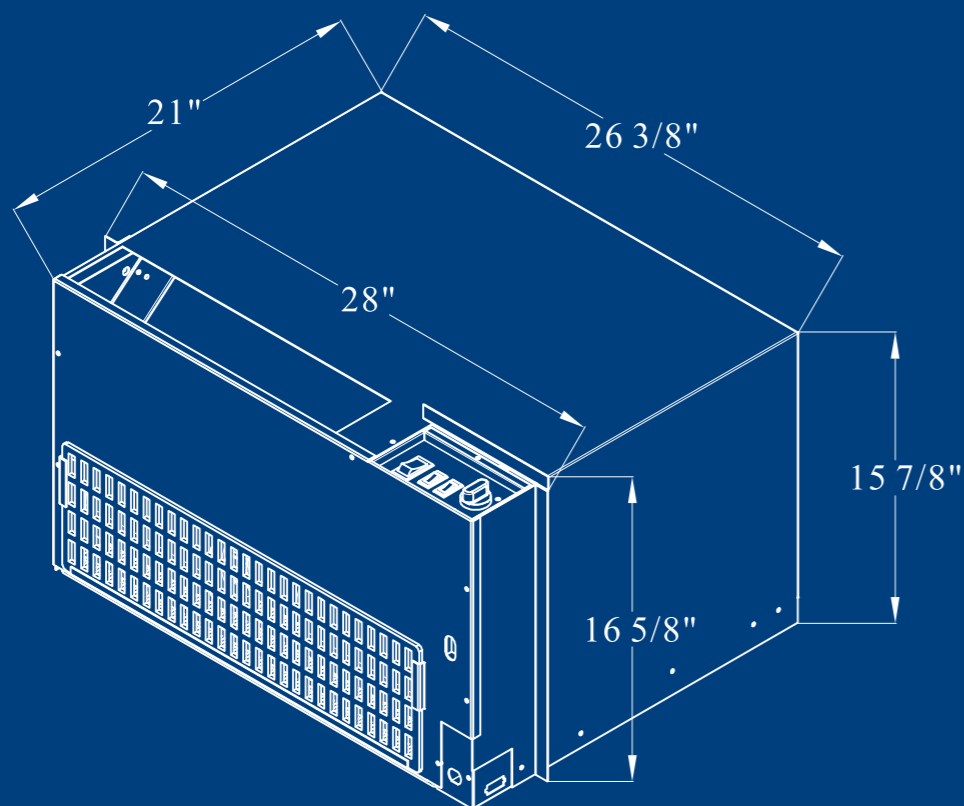

**410A**  
REFRIGERANT



Line Voltage	Maximum Amperage	Wall Socket Configuration	Receptacle Number	Electrical Heat Options
115	16	⊕	NEMA5-20R	3.0-3.5
208/230	12	⊖	NEMA6-15R	3.0-3.5
208/230	16	⊕	NEMA6-20R	3.0-3.5
208/230	24	⊖	NEMA6-30R	3.0-3.5
270	16	⊖	NEMA7-20R	3.0-3.5

- WIRELESS CONTROL IS AVAILABLE
- ANALOG CONTROL AND MAIN THERMOSTAT(OPTION)
- PTC CERAMIC ELECTRIC HEAT OPTION AVAILABLE-CONSULT FACTORY

MODEL	SSMX509H-RS	SSMX809H-RS	SSMX513H-RS	SSMX816H-RS
FAN SPEED	HIGH/LOW	HIGH/LOW	HIGH/LOW	HIGH/LOW
COOLING CAPACITY(BTU/h)	9000/8600	9000/8600	12500/11650	15000/14600
HEATING CAPACITY HOT WATER(BTU/h)	16500/15100	16500/15100	16500/15100	16500/15100
VOLTAGE(V)	115	208	115	208
WATTS(W)	953	993	1422	1815
AIR FLOW(CFM)	300/250	340/300	302/252	346/305
AMPS(A)	8.29	4.84	12.5	8.8
EER	9.44	9.06	8.79	8.26
R410 CHARGE OZ.	28.5	28.2	33.5	34.9
CHASSIS DIMENSIONS(in.)	28"x21"x16 5/8"			
SHIPPING BOX DIMENSION(in.)	30 3/4"x26"x17 3/4"			
WEIGHT(LBS)	139	139	152	152
LOADING(40'/20')				
HEATING CAPACITY STM(BTU/h)	18700/16500	18700/16500	18700/16500	18700/16500

- Important Note: Due to the ongoing development, the performance, specifications, components, and design is subject to change without notice. Please contact factory. All chassis are Tested and Rated in Accordance with ARI 310/380 and UL Standard 484. All "replacement" PTAC chassis are UL Listed for safety and ETL tested.

MODEL  
**SSCL**



FOR THE EXACT REPLACEMENT  
FOR THE:  
RECTROAIRE Rc75  
APPLIED COMFORT DMQ SERIES

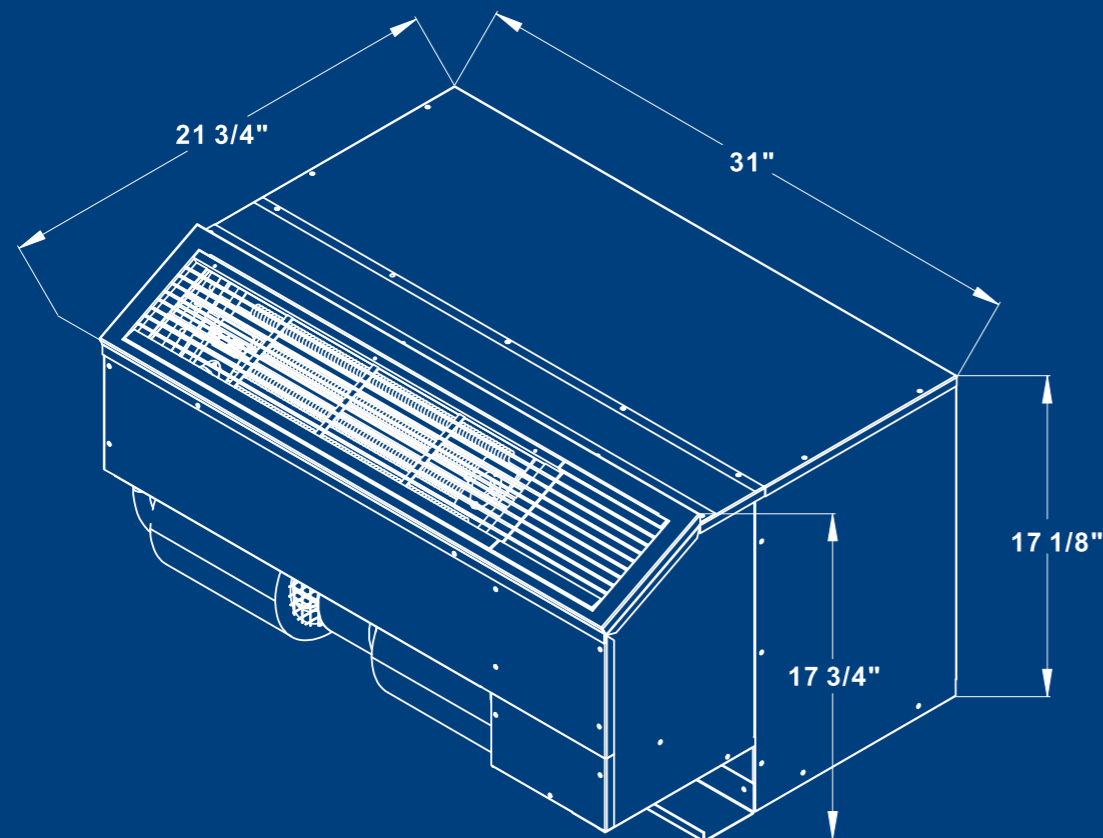

**410A**  
REFRIGERANT



Line Voltage	Maximum Amperage	Wall Socket Configuration	Receptacle Number	Electrical Heat Options
115	16	⊕	NEMA5-20R	3.0-3.5
208/230	12	⊖	NEMA6-15R	3.0-3.5
208/230	16	⊕	NEMA6-20R	3.0-3.5
208/230	24	⊖	NEMA6-30R	3.0-3.5
270	16	⊖	NEMA7-20R	3.0-3.5

- ANALOG CONTROL AND MAIN THERMOSTAT (OPTIONAL)  
PTC CERAMIC ELECTRIC HEAT OPTION AVAILABLE-CONSULT FACTORY

MODEL	SSCL509-TP	SSCL809-TP	SSCL513-TP	SSCL813-TP
COOLING CAPACITY (BTU/h)	9000	8900	11800	12000
HEATING CAPACITY (W) (OPTION)	3.2	3.2	3.2	3.2
HEATING CAPACITY HOT WATER (BTU/h)	16500/15100	16500/15100	16500/15100	16500/15100
VOLTAGE (V)	115V	208V	115V	208V
WATTS (W)	930	920	1320	1340
AIR FLOW (CFM)	350/280	350/280	340/265	340/265
AMPS (A)	8.1	4.4	11.5	6.4
EER	9.68	9.67	8.94	8.96
CHASSIS DIMENSIONS (in.)	31x 21 3/4x17 1/8	31x 21 3/4x17 1/8	31x 21 3/4x17 1/8	31x 21 3/4x17 1/8
SHIPPING BOX DIMENSION (in.)	36 5/8x25 7/8x20 1/2	36 5/8x25 7/8x20 1/2	36 5/8x25 7/8x20 1/2	36 5/8x25 7/8x20 1/2
WEIGHT (LBS)	150	150	154	154
LOADING (40'20')	168/126	168/126	168/126	168/126
HEATING CAPACITY STM (BTU/h)	18700/16500	18700/16500	18700/16500	18700/16500

- Important Note: Due to the ongoing development, the performance, specifications, components, and design is subject to change without notice. Please contact factory.  
All chassis are Tested and Rated in Accordance with ARI 310/380 and UL Standard 484.  
All "replacement" PTAC chassis are UL Listed for safety and ETL tested.

MODEL  
**SSNS/PTH**



AN EXACT CHASSIS REPLACEMENT  
FOR THE PDNS / PDAN MCQUAY  
AND THE CLIMATE MASTER PTH SERIES CHASSIS

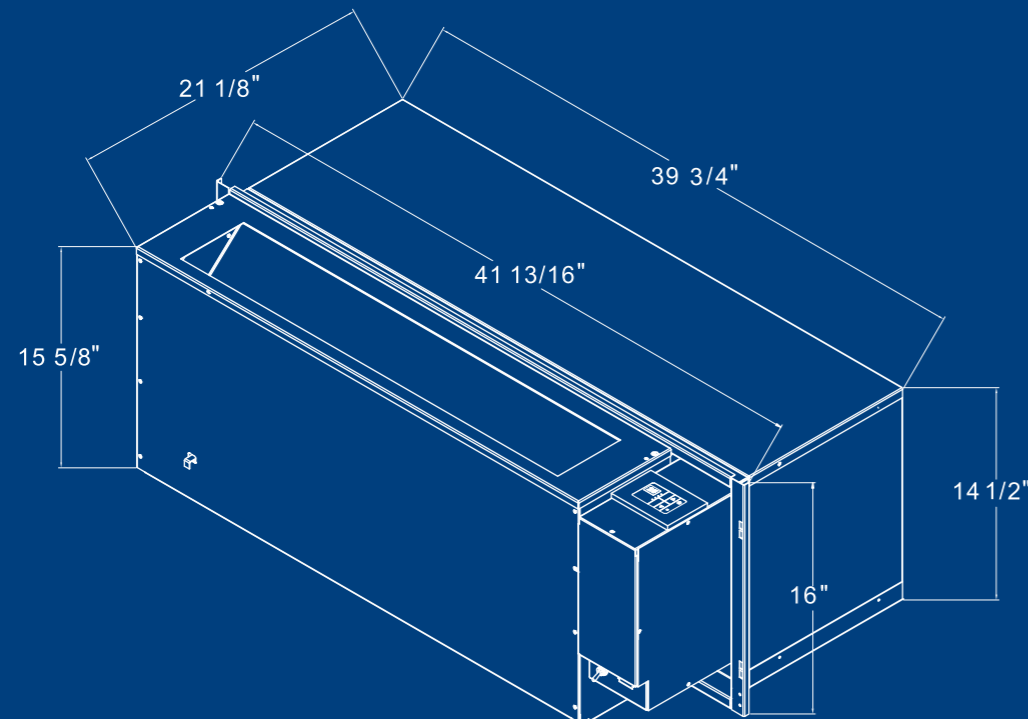

**410A**  
REFRIGERANT



Line Voltage	Maximum Amperage	Wall Socket Configuration	Receptacle Number	Electrical Heat Options
115	16	⊕	NEMA5-20R	3.0-3.5
208/230	12	⊖	NEMA6-15R	3.0-3.5
208/230	16	⊕	NEMA6-20R	3.0-3.5
208/230	24	⊖	NEMA6-30R	3.0-3.5
270	16	⊖	NEMA7-20R	3.0-3.5

- ANALOG CONTROL AND MAIN THERMOSTAT (OPTIONAL)  
PTC CERAMIC ELECTRIC HEAT OPTION AVAILABLE-CONSULT FACTORY

MODEL	SSNS513H-TP	SSNS816H-TP
FAN SPEED	HIGH/LOW	HIGH/LOW
COOLING CAPACITY (BTU/h)	13600	16300
HEATING CAPACITY HOT WATER (BTU/h)	16500/15100	19400/18100
VOLTAGE (V)	115V	208V
WATTS (W)	1320	1710
AIR FLOW (CFM)	370/300	400/300
AMPS (A)	11.5	8.2
EER	10.3	9.5
R410 CHARGE OZ.	40.9	40.5
CHASSIS DIMENSIONS (in.)	39 3/4 X 21 1/8 X 14 1/2	39 3/4 X 21 1/8 X 14 1/2
SHIPPING BOX DIMENSION (in.)	45 1/2 X 25 3/4 X 19 1/2	45 1/2 X 25 3/4 X 19 1/2
WEIGHT (LBS)	146	160
LOADING (40'20')	144/64	144/64
HEATING CAPACITY STM (BTU/h)	18700/16500	20000/19400

- Important Note: Due to the ongoing development, the performance, specifications, components, and design is subject to change without notice. Please contact factory.  
All chassis are Tested and Rated in Accordance with ARI 310/380 and UL Standard 484.  
All "replacement" PTAC chassis are UL Listed for safety and ETL tested.

MODEL  
**SS16NS**



AN EXACT CHASSIS REPLACEMENT  
FOR THE PDNS / PDAN MCQUAY  
AND THE CLIMATE MASTER PTH SERIES CHASSIS

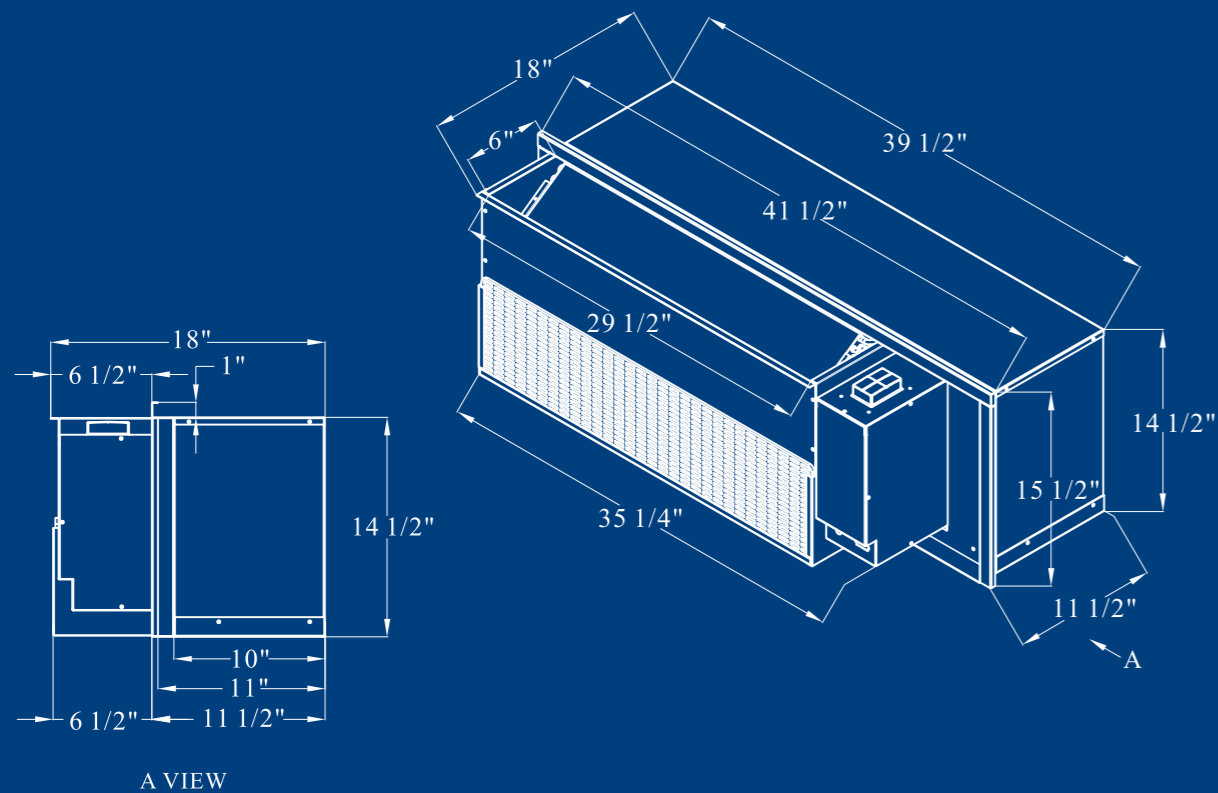

Line Voltage	Maximum Amperage	Wall Socket Configuration	Receptacle Number	Electrical Heat Options
115	16	⊕	NEMA5-20R	3.0-3.5
208/230	12	⊖	NEMA6-15R	3.0-3.5
208/230	16	⊕	NEMA6-20R	3.0-3.5
208/230	24	⊖	NEMA6-30R	3.0-3.5
270	16	⊖	NEMA7-20R	3.0-3.5

- ANALOG CONTROL AND MAIN THERMOSTAT (OPTIONAL)  
PTC CERAMIC ELECTRIC HEAT OPTION AVAILABLE-CONSULT FACTORY

MODEL	SS16NS513H-PCB	SS16NS813H-PCB	SS16NS816H-PCB
FAN SPEED	HIGH/LOW	HIGH/LOW	HIGH/LOW
COOLING CAPACITY(BTU/h)	13600/13200	13950/13750	16130/15500
HEATING CAPACITY HOT WATER(BTU/h)	16500/15100	16500/15100	16500/15100
VOLTAGE(V)	115	208	208
WATTS(W)	1359	1423	1725
AIR FLOW(CFM)	350/312	370/330	370/330
AMPS(A)	11.71	6.9	8.34
EER	10.01	9.8	9.35
R410 CHARGE OZ.	34.6	33.9	37.1
CHASSIS DIMENSIONS(in.)	41 1/2"x18"x15 1/2"		
SHIPPING BOX DIMENSION(in.)	45 1/4"x23 1/4"x17 3/4"		
WEIGHT(LBS)	147	147	150
LOADING(40°/20°)			
HEATING CAPACITY STM(BTU/h)	18700/16500	18700/16500	18700/16500

- Important Note: Due to the ongoing development, the performance, specifications, components, and design is subject to change without notice. Please contact factory.  
All chassis are Tested and Rated in Accordance with ARI 310/380 and UL Standard 484.  
All "replacement" PTAC chassis are UL Listed for safety and ETL tested.

MODEL  
**SSEA**



EXACT CHASSIS REPLACEMENT  
FOR THE:  
REMINGTON, SINGER AND MCQUAY EA,  
ES AND RS SERIES.  
ISLANDAIRE EZ SERIES ED  
ICECAP RSEA

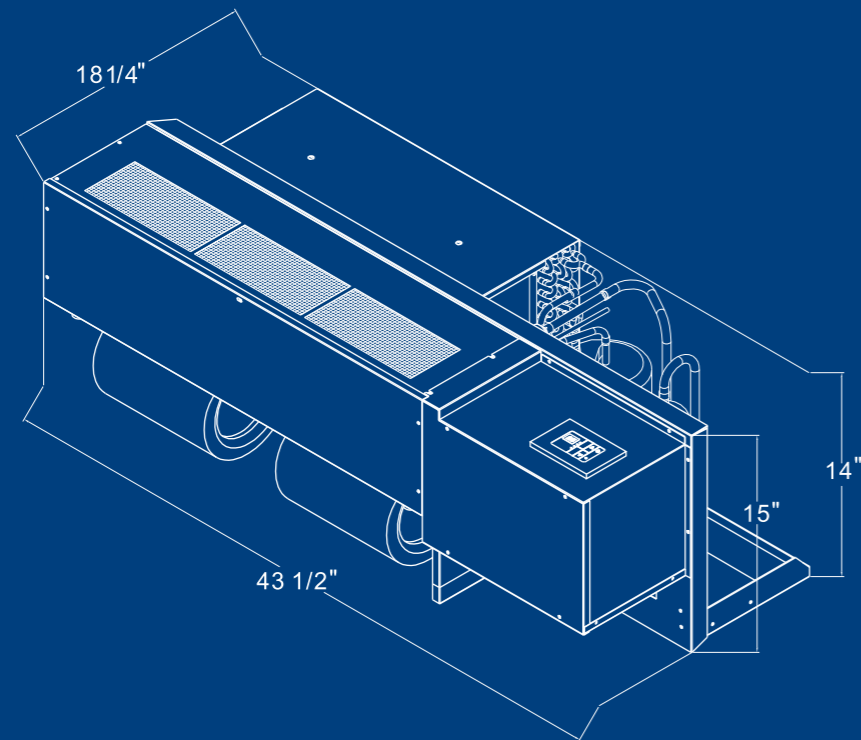

**410A**  
REFRIGERANT



Line Voltage	Maximum Amperage	Wall Socket Configuration	Receptacle Number	Electrical Heat Options
115	16	⊕	NEMA5-20R	3.0-3.5
208/230	12	⊖	NEMA6-15R	3.0-3.5
208/230	16	⊕	NEMA6-20R	3.0-3.5
208/230	24	⊖	NEMA6-30R	3.0-3.5
270	16	⊖	NEMA7-20R	3.0-3.5

- ANALOG CONTROL AND MAIN THERMOSTAT (OPTIONAL)  
PTC CERAMIC ELECTRIC HEAT OPTION AVAILABLE-CONSULT FACTORY

MODEL	SSEA513H-TP	SSEA813H-TP	SSEA816H-TP
FAN SPEED	HIGH/LOW	HIGH/LOW	HIGH/LOW
COOLING CAPACITY (BTU/h)	13600	13500	16000
HEATING CAPACITY HOT WATER (BTU/h)	16500/15100	16500/15100	19400/18100
VOLTAGE (V)	115V	208V	208V
WATTS (W)	1280	1328	1660
AIR FLOW (CFM)	360/300	360/290	390/300
AMPS (A)	11.7	6.4	8.0
EER	10.6	10.2	9.6
R410 CHARGE OZ.	31.7	34.5	38.8
CHASSIS DIMENSIONS (in.)	42 1/2 X 18 1/4 X 14	42 1/2 X 18 1/4 X 14	42 1/2 X 18 1/4 X 14
SHIPPING BOX DIMENSION (in.)	49 X 23 X 18 1/2	49 X 23 X 18 1/2	49 X 23 X 18 1/2
WEIGHT (LBS)	136	136	148
LOADING (40'20')	148/66	148/66	148/66
HEATING CAPACITY STM (BTU/h)	18700/16500	18700/16500	20000/19400

- Important Note: Due to the ongoing development, the performance, specifications, components, and design is subject to change without notice. Please contact factory.  
All chassis are Tested and Rated in Accordance with ARI 310/380 and UL Standard 484.  
All "replacement" PTAC chassis are UL Listed for safety and ETL tested.

MODEL  
**SS40**



EXACT CHASSIS REPLACEMENT  
FOR THE:  
ICECAP CTZS "SLOPE TOP" NARROW  
DEPTH ROOM ENCLOSURE

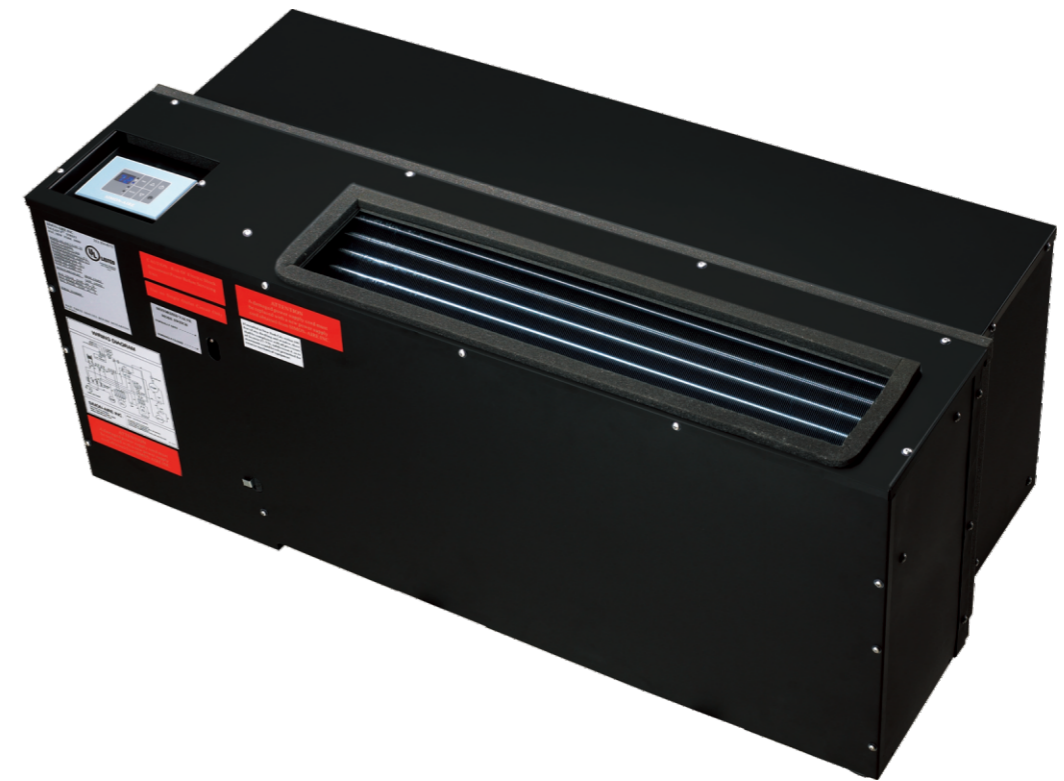
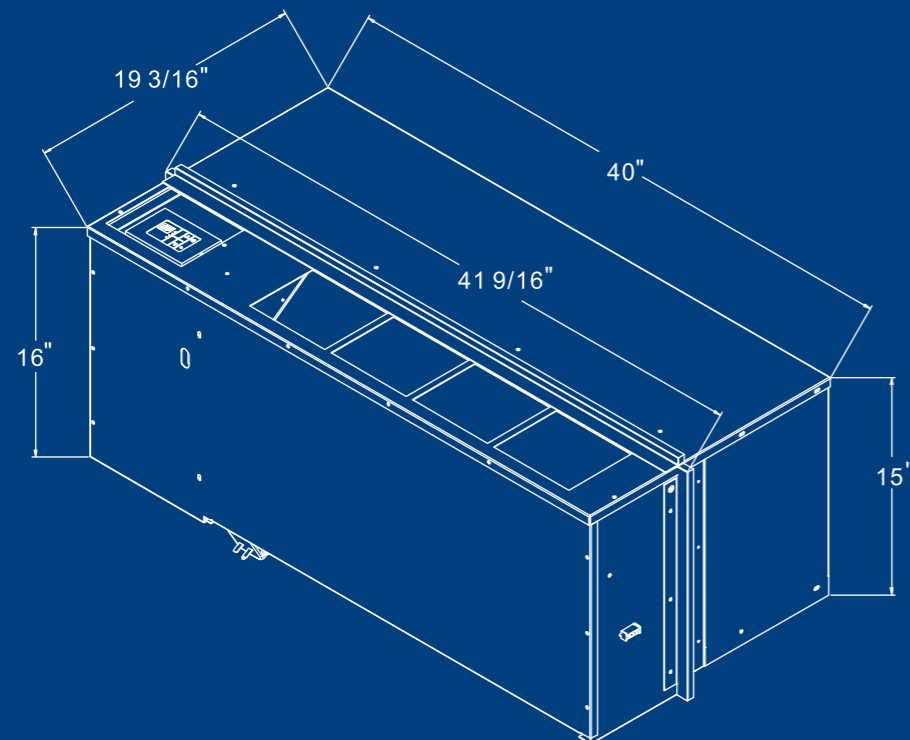

**410A**  
REFRIGERANT



Line Voltage	Maximum Amperage	Wall Socket Configuration	Receptacle Number	Electrical Heat Options
115	16	⊕	NEMA5-20R	3.0-3.5
208/230	12	⊖	NEMA6-15R	3.0-3.5
208/230	16	⊕	NEMA6-20R	3.0-3.5
208/230	24	⊖	NEMA6-30R	3.0-3.5
270	16	⊖	NEMA7-20R	3.0-3.5

- ANALOG CONTROL AND MAIN THERMOSTAT (OPTIONAL)  
PTC CERAMIC ELECTRIC HEAT OPTION AVAILABLE-CONSULT FACTORY

MODEL	SS40 513H-TP	SS40 816H-TP
FAN SPEED	HIGH/LOW	HIGH/LOW
COOLING CAPACITY (BTU/h)	13300	16000
HEATING CAPACITY HOT WATER (BTU/h)	16500/15100	16500/15100
VOLTAGE (V)	115V	208V
WATTS (W)	1330	1690
AIR FLOW (CFM)	390/320	390/300
AMPS (A)	11.8	8.2
EER	10.0	9.45
R410 CHARGE OZ.	37	36
CHASSIS DIMENSIONS (in.)	40X19 3/16X15	40X19 3/16X15
SHIPPING BOX DIMENSION (in.)	47 1/2 X 23 3/4 X 19 3/4	47 1/2 X 23 3/4 X 19 3/4
WEIGHT (LBS)	140	152
LOADING (40'20')	120/52	120/52
HEATING CAPACITY STM (BTU/h)	18700/16500	18700/16500

- Important Note: Due to the ongoing development, the performance, specifications, components, and design is subject to change without notice. Please contact factory.  
All chassis are Tested and Rated in Accordance with ARI 310/380 and UL Standard 484.  
All "replacement" PTAC chassis are UL Listed for safety and ETL tested.

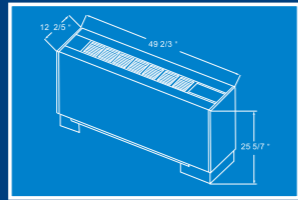
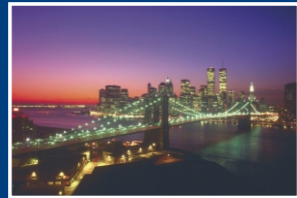

# SSWSHP

## MODEL

WATER SOURCE HEAT PUMP  
REPLACEMENT FOR THE:  
SINGER MODEL WM AND THE  
WATER FURNANCE MODEL CC

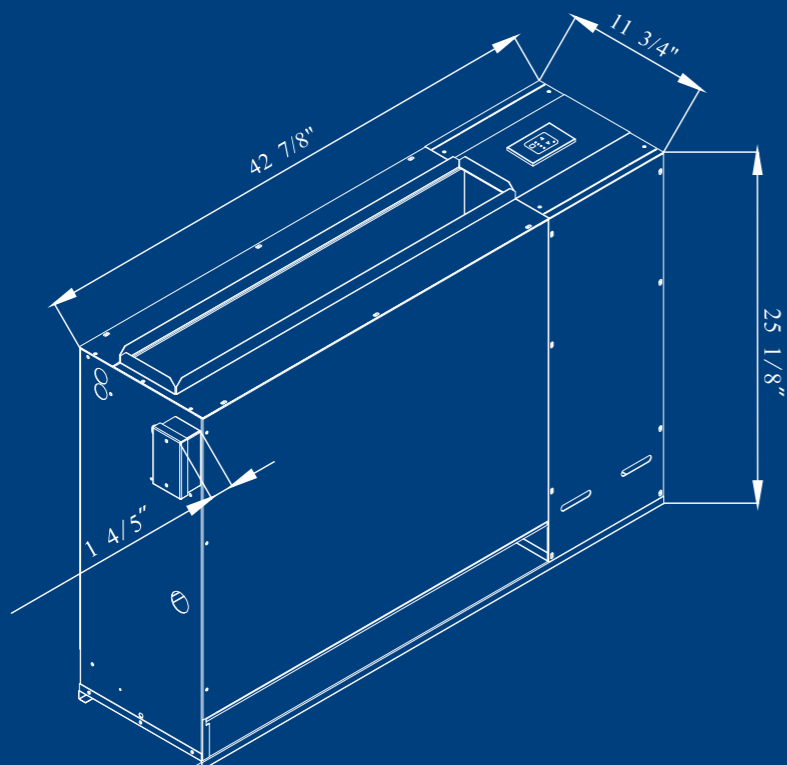

MODEL	SSWSHP512	SSWSHP812	SSWSHP818
FAN SPEED	HIGH/LOW	HIGH/LOW	HIGH/LOW
COOLING CAPACITY (BTU/h)	13000	13500	20500
HEATING CAPACITY (BTU/h)	15500	16500	21500
VOLTAGE (V)	115V	208V	208V
WATTS (W)	920	950	1280
AIR FLOW (CFM)	400/300	360/300	560/450
AMPS (A)	8.6	4.6	6.3
COP	4.77	4.7	5.1
EER	14.2	14.3	16
FREON CHARGE OZ.	24.7	24.7	35.3
CHASSIS DIMENSIONS (in.)	37 7/8 X 10 1/4 X 25 1/8	37 7/8 X 10 1/4 X 25 1/8	42 7/8 X 11 3/4 X 25 1/8
SHIPPING BOX DIMENSION (in.)	48 3/4 X 28 3/4 X 15	48 3/4 X 28 3/4 X 15	53 1/2 X 31 1/4 X 16 1/4
WEIGHT (LBS)	183	183	220
LOADING (40'20')	108/50	108/50	80/40

• Important Note: Due to the ongoing development, the performance, specifications, components, and design is subject to change without notice. Please contact factory.  
All chassis are Tested and Rated in accordance with ISO 13256-1 and UL484, UL1995.  
All "replacement" chassis are UL Listed for safety and ETL tested.

MODEL  
**SSWSFC**



WATER SOURCE HEAT PUMP  
NEW CONSTRUCTION AND AS AN EXACT  
REPLACEMENT FOR THE  
FRIEDRICH CLIMATE MASTER 800 SERIES

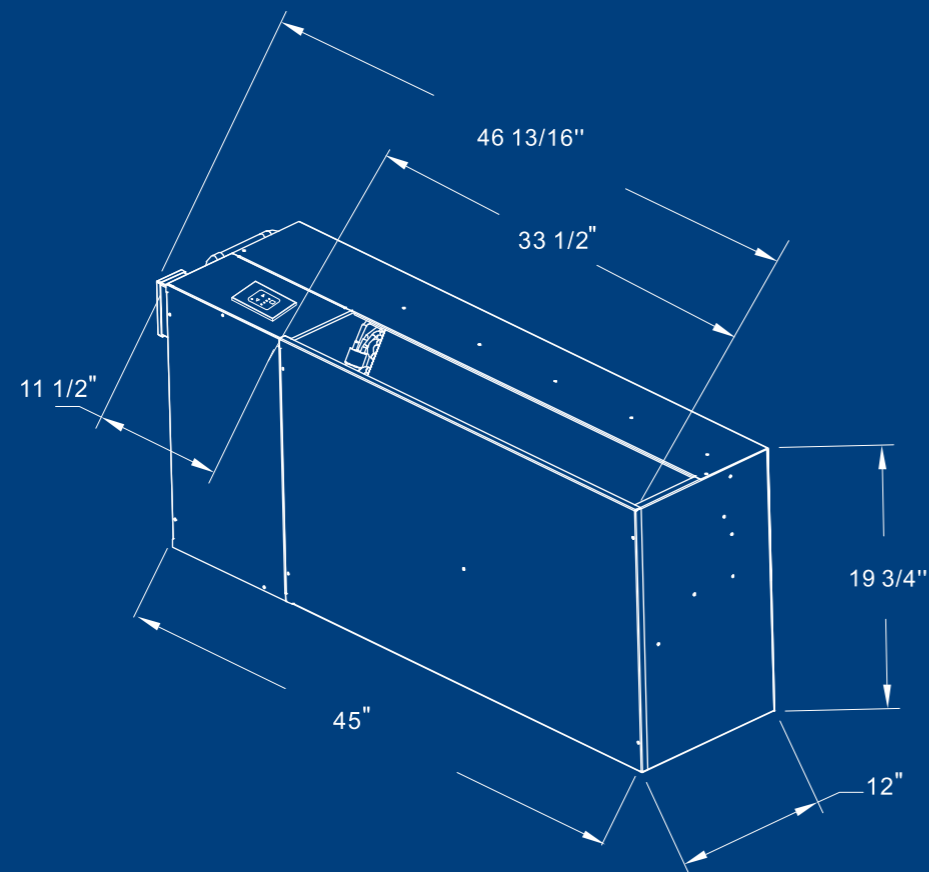

MODEL	SSWSFC512	SSWSFC812	SSWSFC818
FAN SPEED	HIGH/LOW	HIGH/LOW	HIGH/LOW
COOLING CAPACITY (BTU/h)	13000	13500	20500
HEATING CAPACITY (BTU/h)	15500	16500	21500
VOLTAGE (V)	115V	208V	208V
WATTS (W)	920	950	1280
AIR FLOW (CFM)	400/300	360/300	560/450
AMPS (A)	8.6	4.6	6.3
COP	4.77	4.7	5.1
EER	14.2	14.3	16
FREON CHARGE OZ.	24.7	24.7	32.5
CHASSIS DIMENSIONS (in.)	41X12X19 3/4	41X12X19 3/4	45X12X19 3/4
SHIPPING BOX DIMENSION (in.)	47 1/2 X 16 3/4 X 21 3/4	47 1/2 X 16 3/4 X 21 3/4	49 3/4 X 15 X 24 1/2
WEIGHT (LBS)	138	138	176
LOADING (40'20')	138/66	138/66	92/44

• Important Note: Due to the ongoing development, the performance, specifications, components, and design is subject to change without notice. Please contact factory.  
All chassis are Tested and Rated in accordance with ISO 13256-1 and UL484, UL1995.  
All "replacement" chassis are UL Listed for safety and ETL tested.



## PARTS & ACCESSORIES



### HYDRONIC HEAT ASSEMBLIES

Heat assemblies are available configured to suite the design elements of the building system. They are available in right handed supply and left handed supply as well as all handed same side.

We can also configure the heat assemblies to include attachment of the motorized valve and protective construction covers for the coil elements to protect the coil fins during construction.

All heating coils are rated to maximum test pressures and double welded to insure safety and integral.

The heat coil cradle is a integral company attached directly to the chassis wall sleeve. This attachment insures a solid base for the completion of the steam fitting work and provides a built in chassis to heat assembly tolerance for the air tight interface to the chassis, to heat assembly ,to discharge grille and room enclosure.

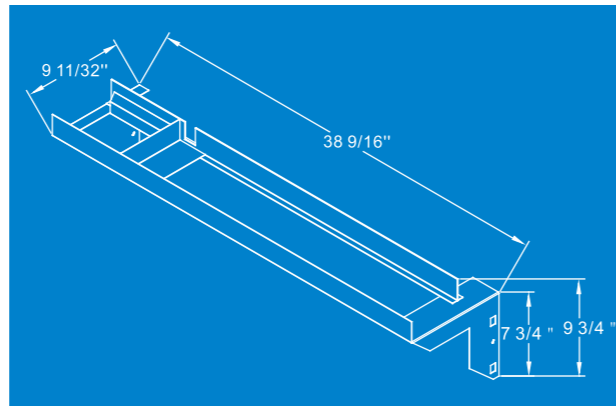
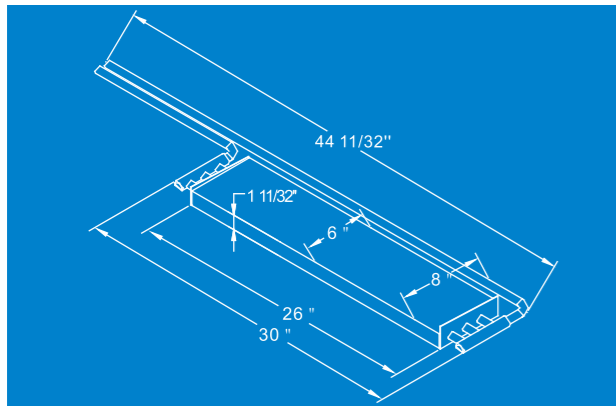

### OUTSIDE LOUVERS:

The Simon-Aire extruded aluminum architectural outside louver is available in the full range of paint colors(ie Benjamin Moore ect). The outside louver is attached directly to the wall sleeve via four attachment (machine nut and bolt) points assuring safety and a solid attachment. The louvers are available in a Bronze Anodized finish as well as painted finishes, to match your architectural designs.

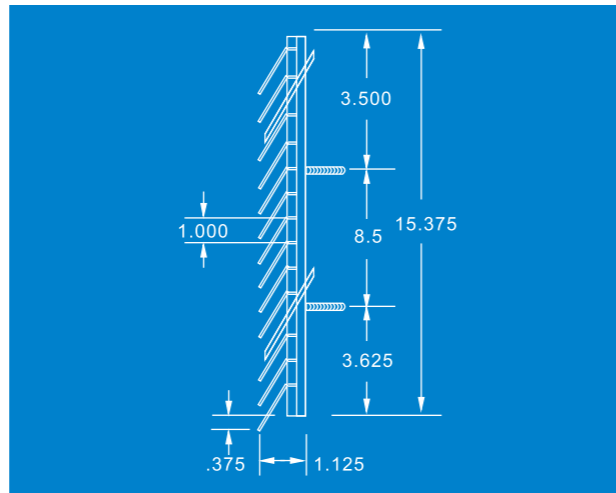
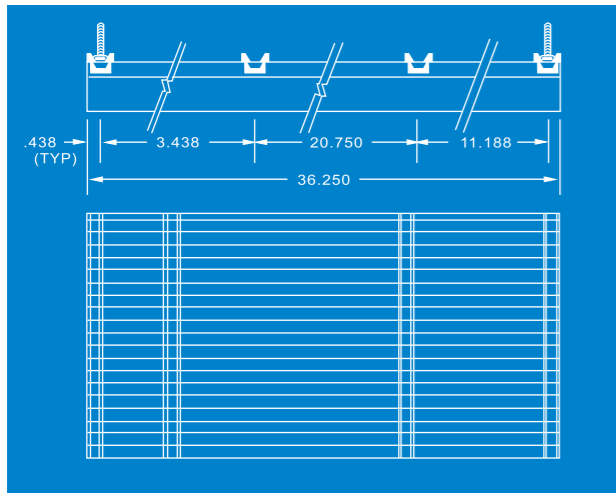

## PARTS & ACCESSORIES



### WALL SLEEVE:

The Simon-Aire wall sleeves are available in a full range of sizes and styles to suite your specific building construction. We have the capability to produce any dimension of Masonry wall sleeves as well as window wall and panel wall interfacing sleeves. Optional brick stops and undercoating is Available.

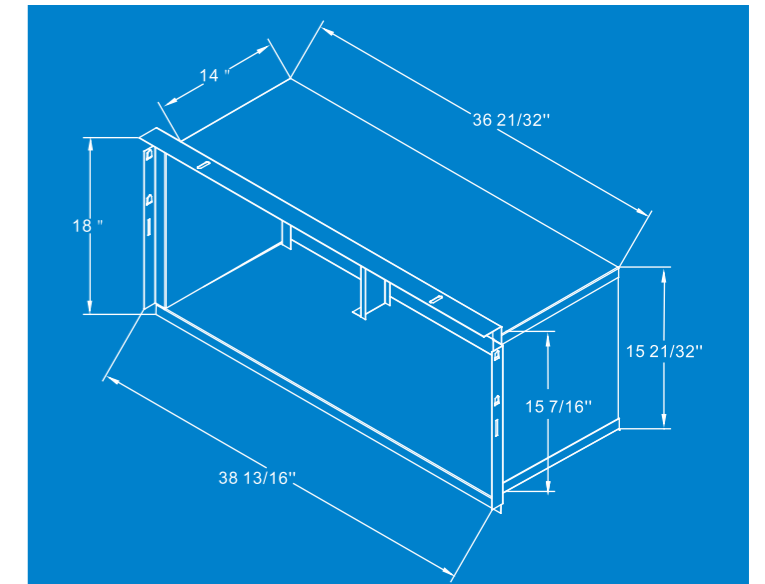

### SIMON-AIRE PTC CERAMIC HEATER ELEMENT:

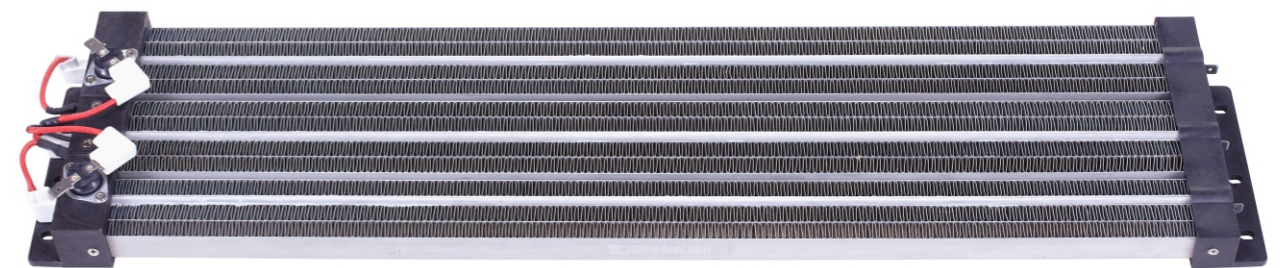

**PTC Ceramic Heater Element (Optional)** – The Simon-Aire Positive Temperature Co-Efficient Heating Element is a distinct advantage and upgrade from the standard nickel element or wiretype heater element. They are self-regulating and ensure safety and will provide a stable dynamic energy efficiency and long life reliability.

**Automatic Safety Control** –The PTC element heater is self limiting, having an internal intrinsic stability function without the danger of overheating or combustion.

**Energy Consumption and Savings** – The energy input of the Simon-Aire PTC Ceramic Heater is controlled by the rational expression along with the current limiting function. Its power saving capability exceeds the nickel and chromium wire types.

**Longer Life Span** – The Simon-Aire PTC heater design is a component that will last the life time of the unit.

**PARTS AND OPTIONAL CONTROLS**

The Simon-Aire chassis incorporate the best components available today.  
 The ISO quality IQC process insures that each component is tested to our strict specifications and requirements.  
 All parts are available thru the Simon-Aire factory parts department.

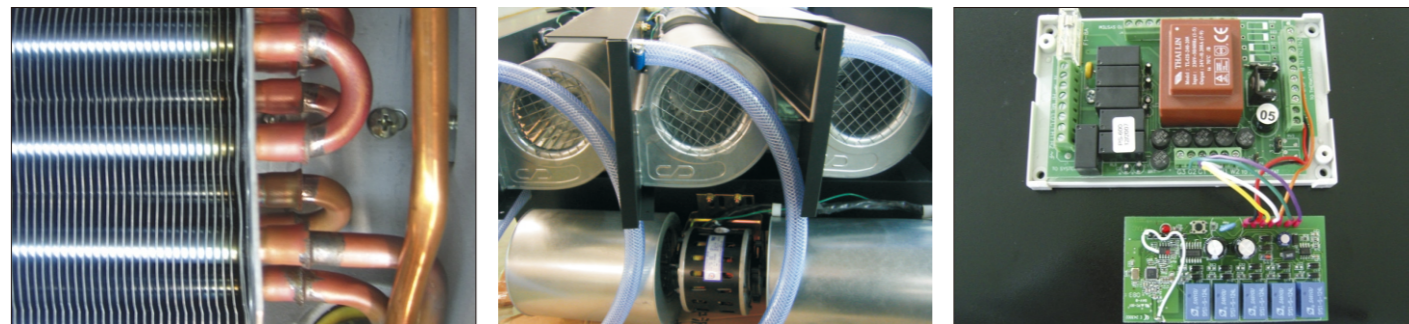
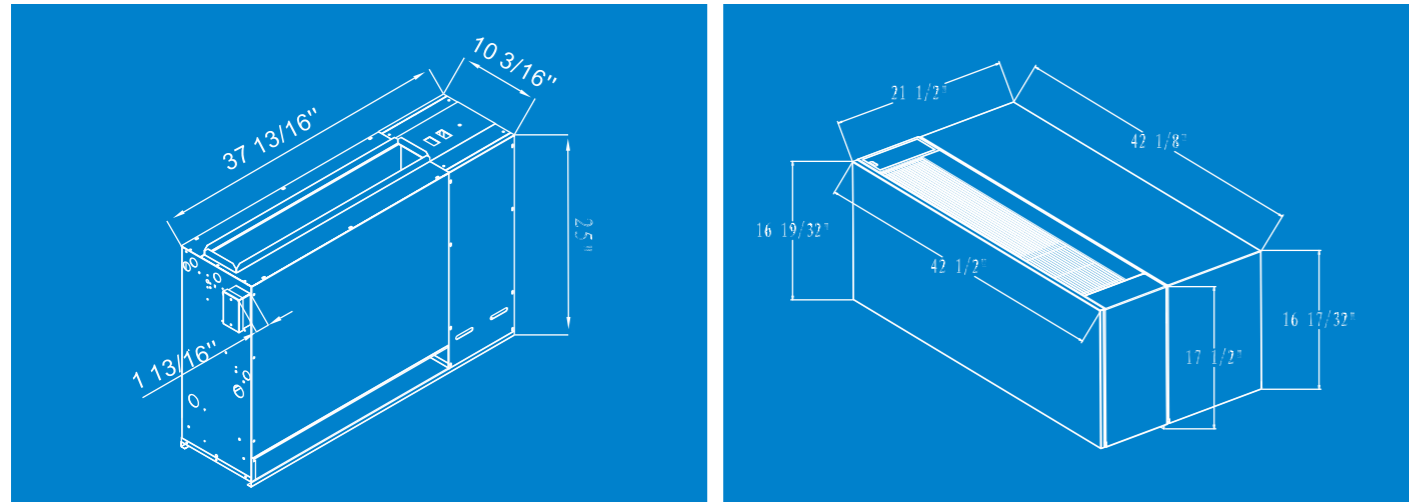

**SIMON-AIRE TOUCH PAD COMES PLUG AND PLAY READY TO BE WALL MOUNTED.**

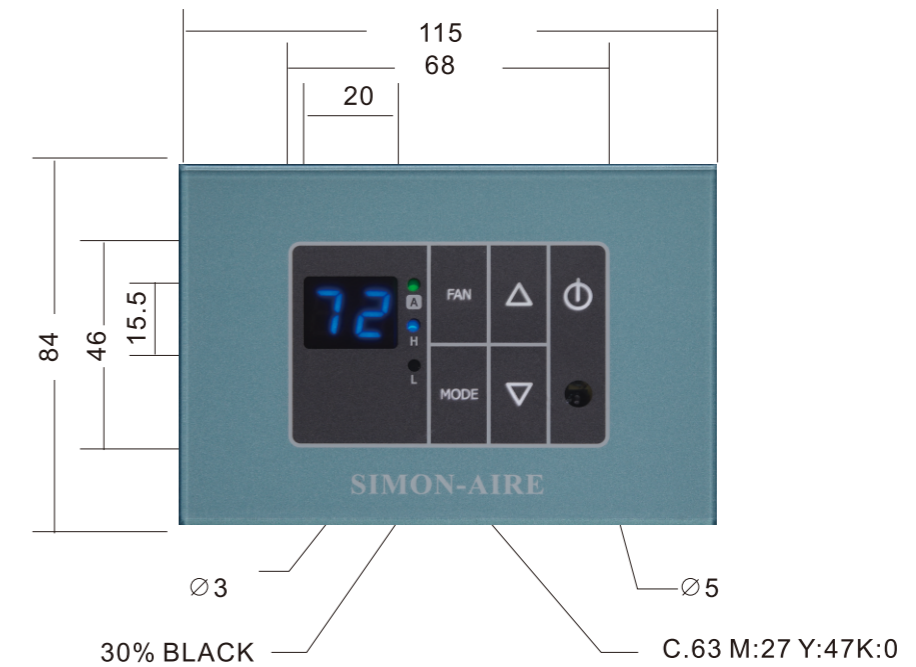

The Simon-Aire "Touch-Pad" can be removed from the chassis by a qualified HVAC technician and wall mounted via the provided two wire hook up and mounted in a standard single gang box or with the included wall mount box.

In addition the Touch-pad control can be hidden from view as the room temp sensing devices are located within the cooling chassis. Optional hand held controller is also available. The Touch-Pad fascia is also available in a Neutral Bone White Color.

The Simon-Aire Chassis can be factory ordered to interface with standard 24V Standard wall thermostat as well as with the CRESTRON, ENERNET and INNCOM Home Automation and front desk control system.



## SIMON-AIRE REMOTE HAND HELD CONTROLLER



### LCD REMOTE 7

By means of advanced microprocessor technology and infrared transmission, LCD5.1 brings convenient and accurate room temperature control to its user. It also provides many energy saving features such as FAN AUTO, SLEEP, TIMER functions.

### CONTROL BUTTONS:

#### POWER BUTTON

Press **⏻** to turn on/off air conditioner.

#### MODE BUTTON

##### Cool only Model

Press MODE to change mode of operation from FAN, COOL, DRY.

##### Heat/Cool Model

Press MODE to change mode of operation from FAN, COOL, DRY, HEAT, AUTO.

Operating mode will be displayed on the remote.

#### TEMPERATURE SETTING BUTTONS

Press **▲** or **▼** to change setting temperature.

#### FAN SPEED BUTTON

Press **🌀** to change fan speed.

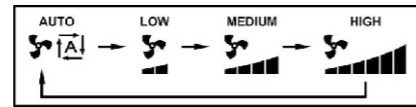

#### SLEEP BUTTON

Press SLEEP and the **🌙** will be displayed, the settign temperature will be automatically raised 2F after one hour in COOL MODE, but will decreased 2 F in HEAT MODE to save energy, and the **🌙** will be disappeared as well.

#### CLOCK SETTING

To set clock on the remote unit

- Press **🕒** and **🕒** at LCD will blink.
- Press **▲** Or **▼** to set time.
- Press **SEND** to confirm setting.

#### TIMER SETTING

The air conditioner can be programmed to turn on/off in advance.

- Press **🕒 ON** or **🕒 OFF**, the symbol ON or OFF and time will be blinking
- Press **🕒 ON** or **🕒 OFF** button to change the timer, Hold the button for fast changing
- Press **🕒 ON** or **🕒 OFF** again, the symbol ON or OFF and time will stop blinking

#### CANCEL TIMER

- Press **🕒 ON** or **🕒 OFF** again to cancel Timer on/off

#### SWEEP BUTTON (OPTION)

Press SW to turn on/off SWEEP Motor

#### KEYLOCK

Press and hold the **🔒** button for 2 seconds will lock all the buttons on the remote unit.

The **🔒** symbol is displayed. To unlock ,press and hold the **🔒** button for 2 seconds.

## SSK ROOM ENCLOSURE



### SSK ENCLOSURE DETAIL VIEW

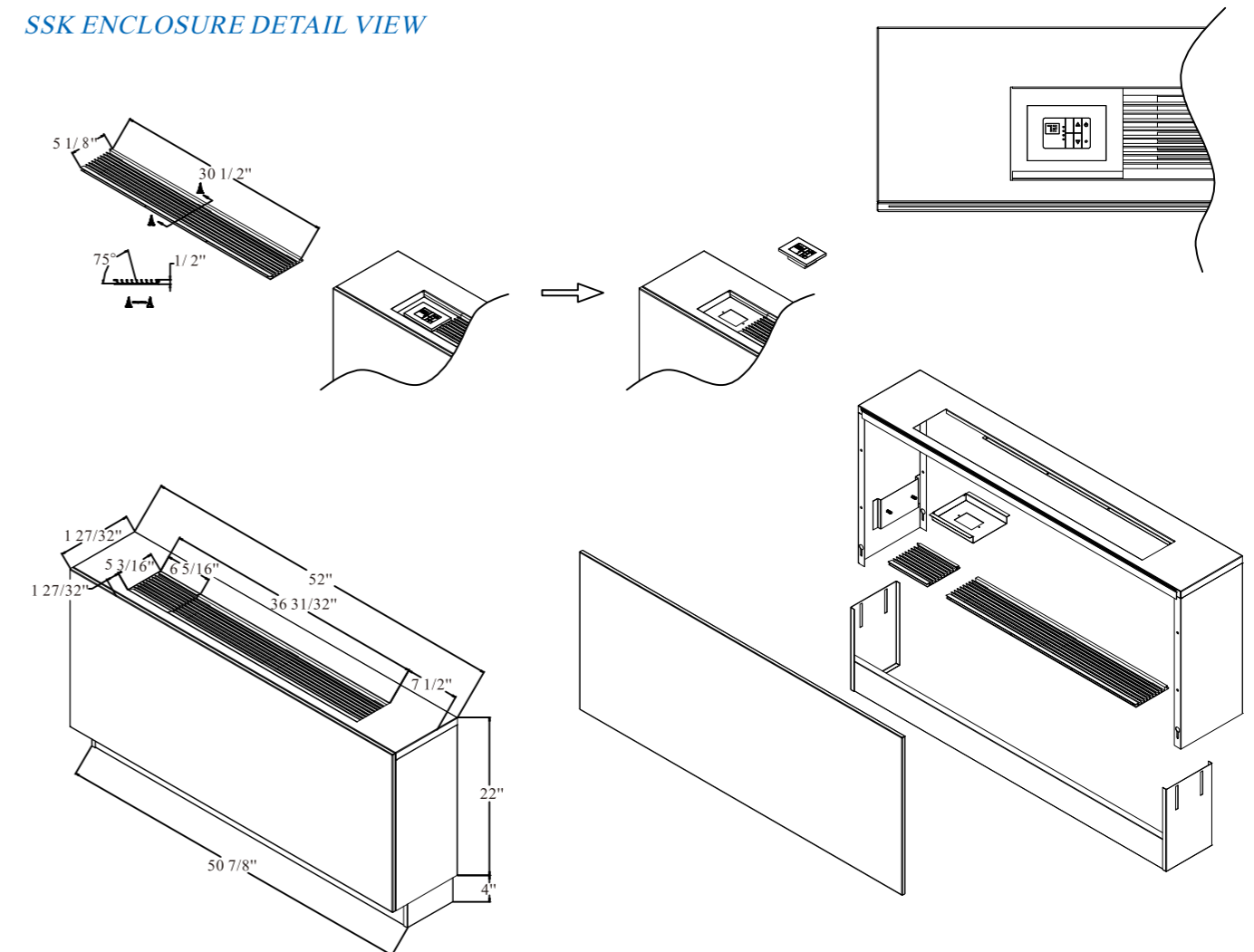

# SIMON-AIRE INC.

## SUBMITTAL DATA



# SIMON-AIRE INC.

**The Simon-Aire Chassis** --Will be furnished and installed as indicated within the mechanical specifications in the locations and capacities noted. The units will be located as shown on the drawings and shall include the optional room enclosure, wall sleeve, cooling chassis, digital Touch-Pad, Outdoor Louver, Steam / Hot Water Heat Assembly. All units shall be NY buildings Department MEA approved, UL Listed for Safety and ARI certified for performance. Overall dimensions of the room enclosures shall not exceed 52" wide, 22-1/2" high and 10 -1/2" deep. Wall sleeves shall be fabricated to match the dimensional details of the building wall.

**Heating/Cooling Chassis** --Chassis shall be industrial grade slide in PTAC type with a self-contained, hermetically sealed refrigerant circuit. All chassis sheet metal parts shall be constructed of heavy-gauge galvanized steel and deposition electrostatic coated for maximum corrosion resistance and long life.

The chassis shall consist of the following component:

vibration isolated compressor; rifled copper tubed evaporator and condenser coils with high efficiency aluminum plat fins mechanically expanded to the tubes for maximum heat transfer; and a capillary type metering device. Coils shall be factory tested at 300 psig.

The condenser section shall consist of a separate single speed , fan cooled, psc outdoor condenser motor.

Condenser fan shall be made of aluminum and hi speed balanced.

Propeller type with a slinger ring. Indoor fan motor shall be two speed and shall be separate from the outdoor condenser fan motor. The evaporator fan motor must be positioned on the indoor side of bulkhead so as to be completely within the conditioned, filtered airstream. Both the indoor and outdoor fan motors shall be permanently lubricated type for prolonged life. Indoor fans shall be curved centrifugal type to provide even airflow across the evaporator coil.

**Heating Coil** --Heating assembly shall consist of pre-assembled cradle and heating coil. Coils are copper tubes and mechanically expanded into aluminum fins

**Cooling Cycle** --The compressor , the outdoor fan motor and the indoor fan motor shall be energized. Condensation accumulated on the evaporator coil shall be drained into the outdoor section where it is to be picked up by the condenser fan and evaporated against the outdoor coil.

**Heating Cycle** --Only the indoor fan motor, the (normally open ) (normally closed) valve.

Outdoor condenser fan motor and compressor shall not be energized.

**Mode And Function Controls** --The Simon-Aire chassis where noted will be provided with the Digital Touch-Pad system or Rocker Switch controls.

**Room Enclosure** --Shall be flat top , wrap-around design with a heavy-gauge sheet metal front panel that is coated with a baked on , antique white corrosion resistant finish. (Consult factory for other available finisheds).

**Wall Sleeve** --Shall be entirely constructed of galvanized metal sheet with welded seams.

**Outside Air Louvers** --Shall be (architectural) anodized aluminum. Louver shall be (finished natural) or (painted). Louvers can be easily installed from the inside of the building after the cabinet/wall sleeve has been installed.

**R410A** --All Simon-Aire chassis utilize R410a Refrigerant and Compatible Compressors, Coils and Tubing.

# SIMON-AIRE INC.

SIMON-AIRE INC. 746 East 9th Street, New York 10009  
Tel: 212-254-8372  
Fax: 646-349-5921  
E-mail: [engineering@simon-aire.com](mailto:engineering@simon-aire.com) / [sales@simon-aire.com](mailto:sales@simon-aire.com)  
[www.simon-aire.com](http://www.simon-aire.com)



COME SEE US AGAIN  
IN 2019 IN ATLANTA

